

Enhanced integration of LiFi with 5G core and services

Maximilian Riegel
LiFi Conference, 24. June 2021



Fully leveraging LiFi capabilities through enhanced integration with 5G core and services

Abstract:

LiFi has superior capabilities compared to other licensed-exempt wireless technologies like Wi-Fi / IEEE 802.11. Current deployment models mainly treat LiFi like the common licensed-exempt technologies missing the possibility to fully exploit the potential performance of light communications.

The presentation will show where common Wi-Fi interworking models for the integration with 5G core and services fall short in fully leveraging LiFi capabilities, and what steps have to be taken in development and standardization to overcome the shortcomings in the current approaches.

Maximilian Riegel received his Dipl.-Ing. degree in Electrical Engineering from TU Munich, Germany and is currently responsible for IEEE & Wi-Fi standardization within Nokia. He participates in IEEE 802 and other Wi-Fi related standardization for more than 15 years and led the development of IEEE 802.11CF-2019 specification. He was NWG vice chair in the WiMAX Forum, led the Ethernet over cellular work in IETF 16ng WG, and chaired the OmniRAN SG/TG activities in IEEE 802. He regularly acts as lecturer for Wi-Fi and as speaker at technical conferences. Formerly, he held R&D management positions within Siemens Communications and Philips Communication Industry.

Nokia creates technology that helps the world act together. As a trusted partner for critical networks, Nokia is committed to innovation and technology leadership across mobile, fixed and cloud networks. It creates value with intellectual property and long-term research, led by the award-winning Nokia Bell Labs. Adhering to the highest standards of integrity and security, Nokia helps to build the capabilities needed for a more productive, sustainable and inclusive world.



On the path of the 4th industrial revolution

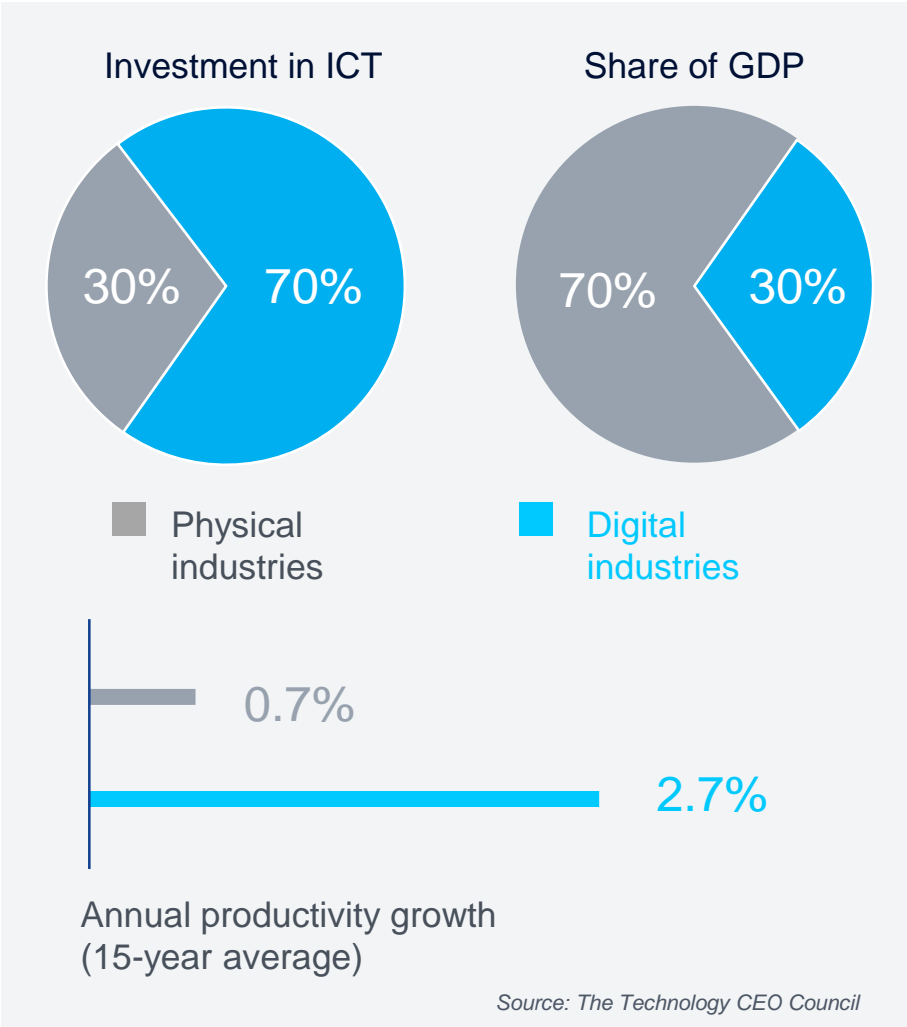

On the path of the 4th industrial revolution

...and this is happening NOW

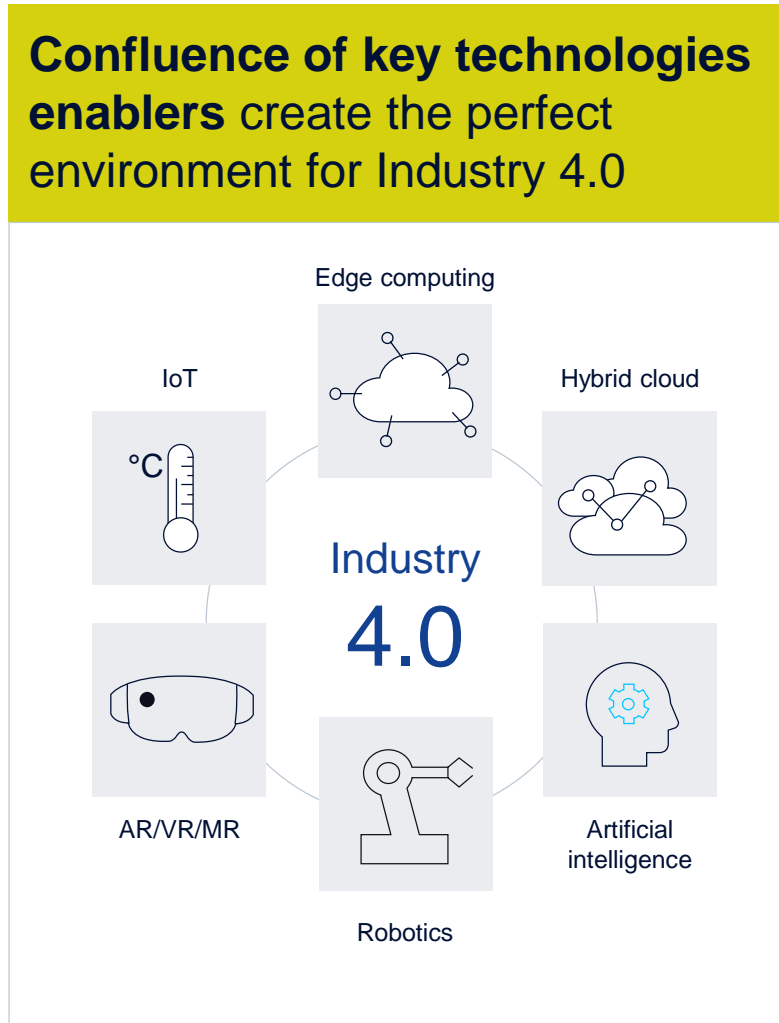
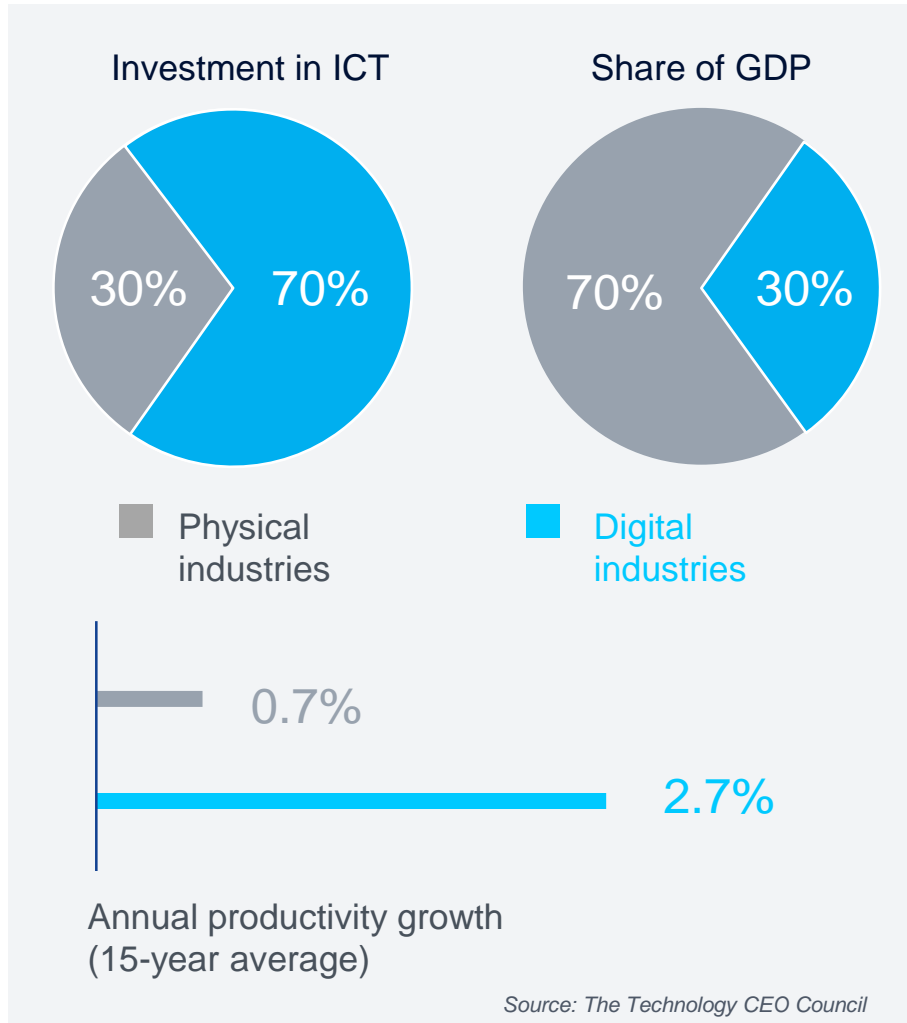

>70%
enterprise are investing in IIoT today

<https://www.pwc.pt/pt/temas-actuais/pwc-apresentacao-iiot.pdf>

49%
IT are reporting working closer with Operational Technologies on IIoT projects (32% in 2018)

451 research - Internet of Things, Organizational Dynamics 2019

Industry 4.0 use cases enabled by 3GPP 5G evolution

Offered through 5G Private Wireless to industries

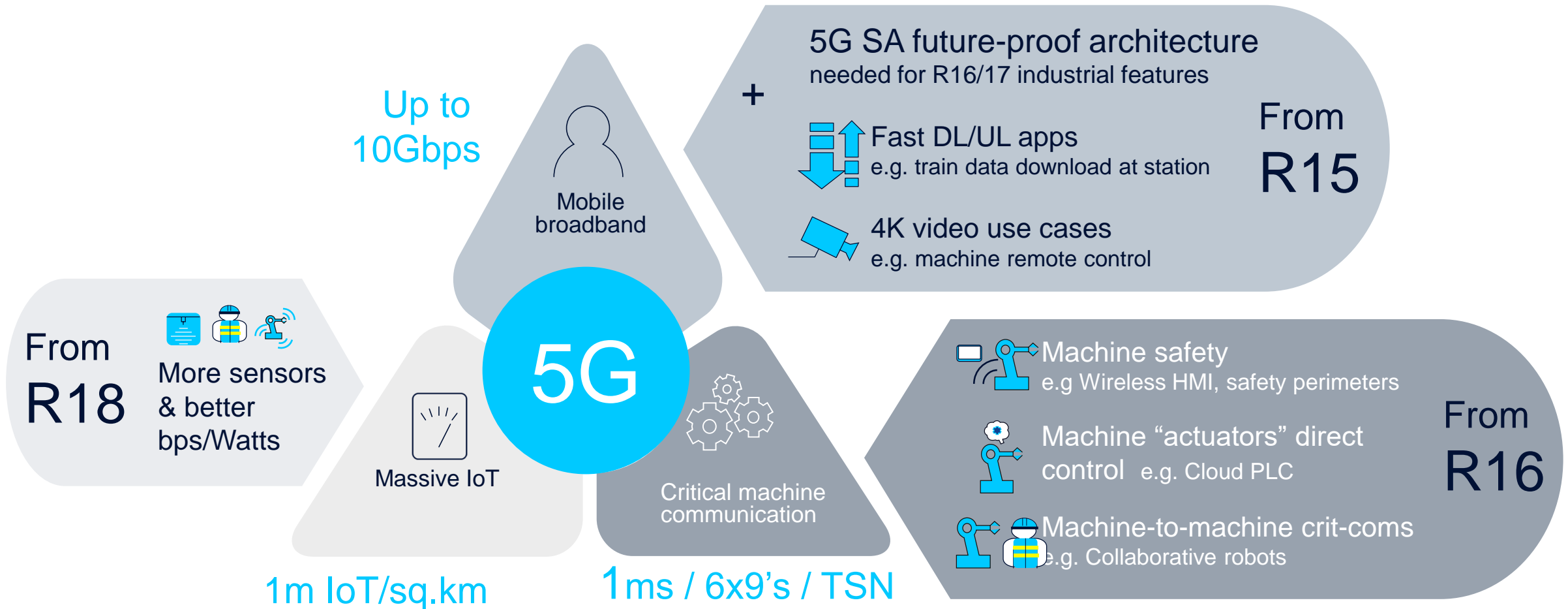

Challenging connectivity options to address Industry 4.0 needs

When wires have to be replaced by wireless...

LAN cables & wired technologies

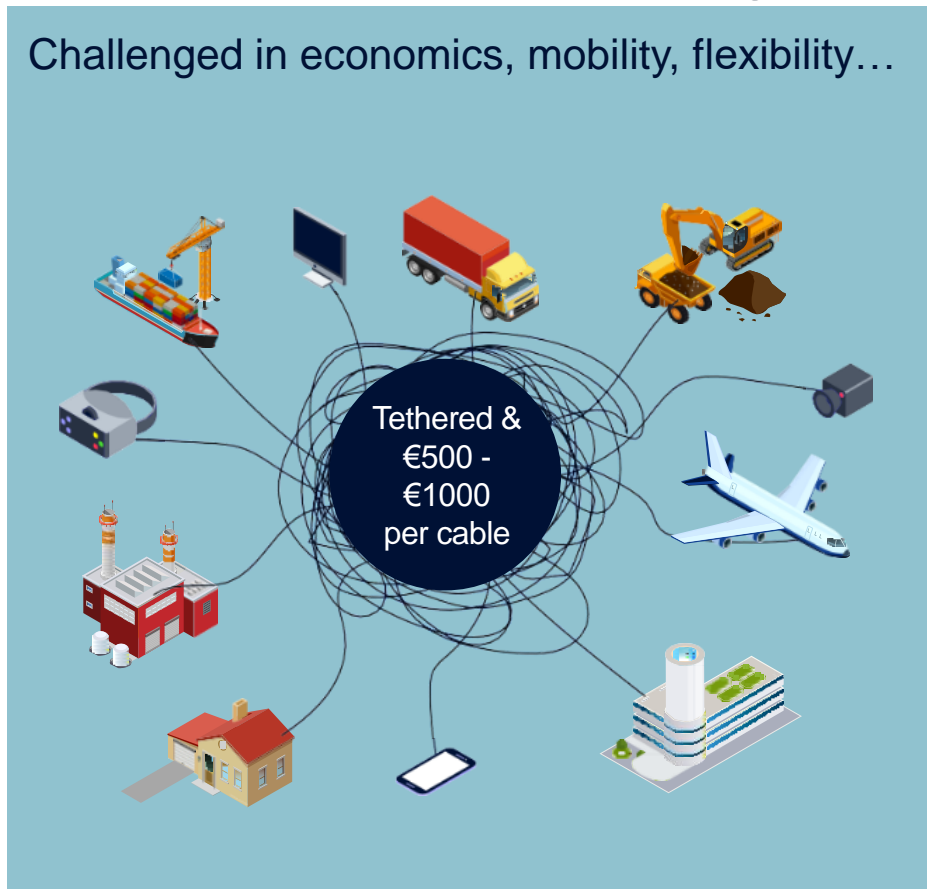

Wireless technologies challenges

Use-case class	Service availability	Message size/data rate Traffic	Wireless system E2E latency target value	Device speed
Process devices, e.g. motion control	99.999%	50 B / 800 kbps Deterministic, periodic	0.5-1 ms	<30 kmph
Logistic devices, e.g. collaborative robots	99.9999%	50-250 B / 12 Mbps Periodic, aperiodic	5-50 ms	<30 kmph
Augmented reality	99.99%	1500 B / 10-80 Mbps Periodic, aperiodic	4 ms	<8 kmph
Logistic devices, e.g. autonomous robots	99.99%	100 B / low Aperiodic	40-500 ms	<15 kmph
Asset/Process monitoring	99.99%	250 kB / ≤2 Mbps Periodic	100 ms up to multiple seconds	Stationary

Connectivity performance comparison in an industrial environment

Latency vs reliability of Ethernet, 4G/5G, and Wi-Fi

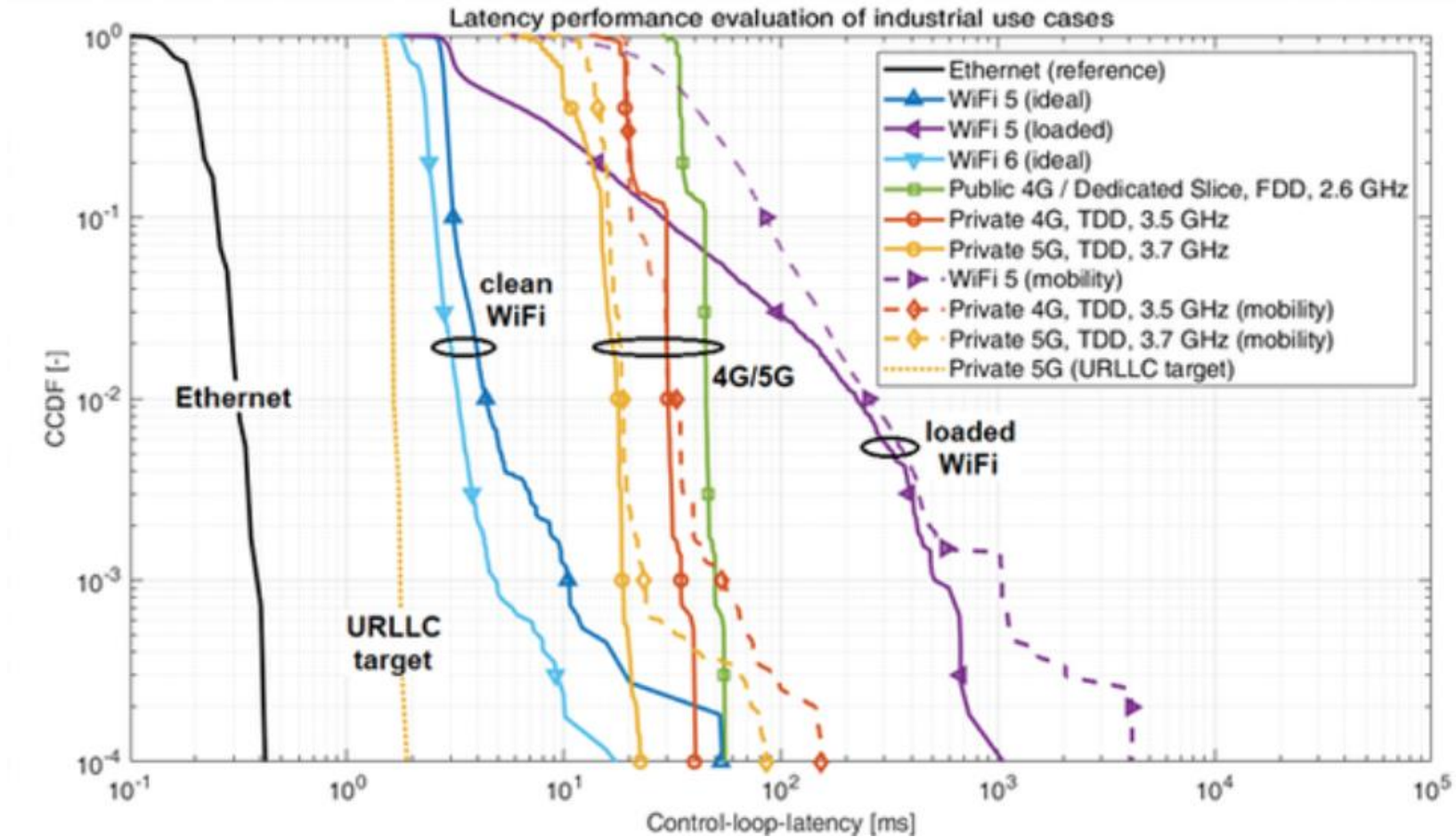

Connectivity performance comparison in an industrial environment

LiFi could fill the gap

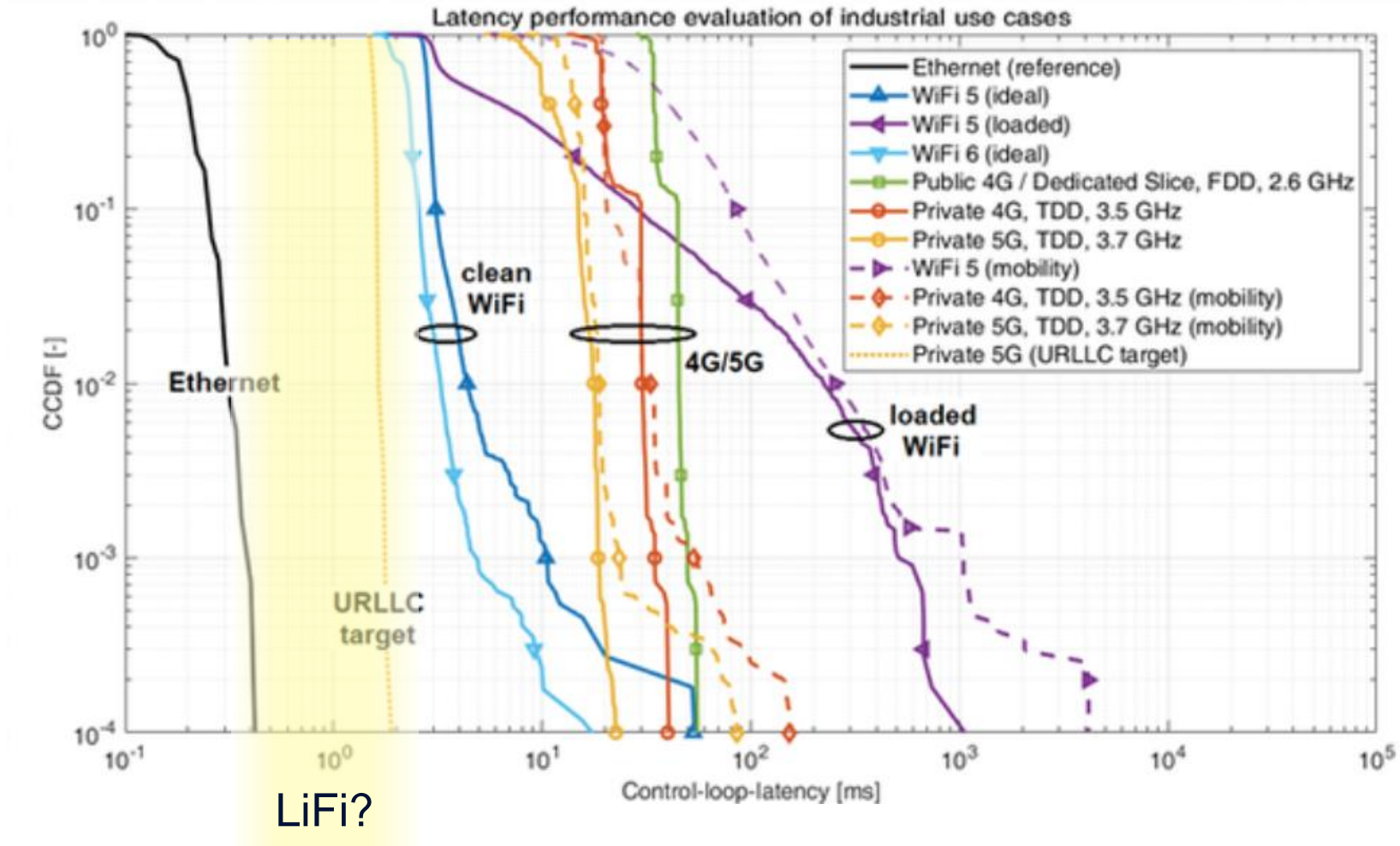

How to integrate LiFi into 5G?



5G Architecture: Reference Point Representation

Access networks are connected through N2 and N3 interface

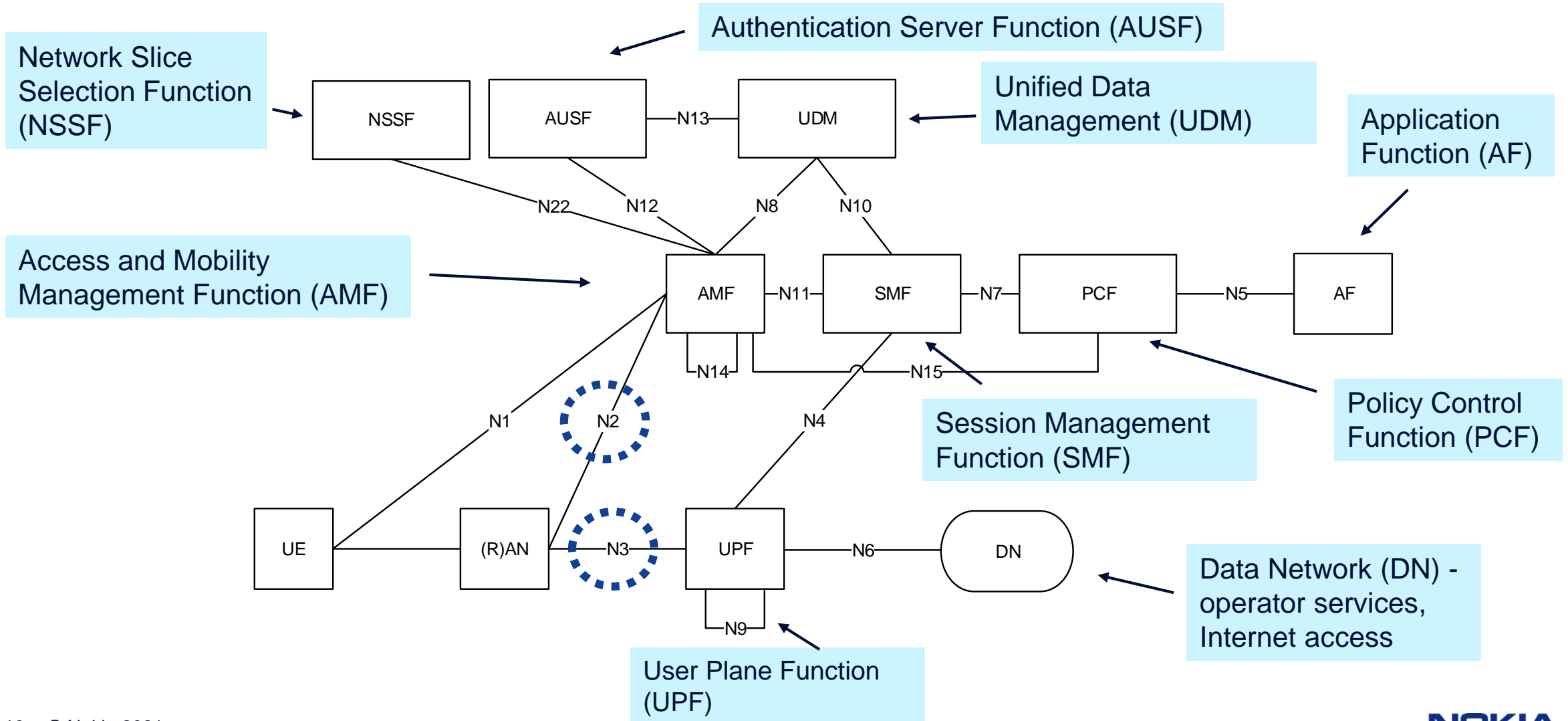

5G QoS model to provide fine-grain service differentiation

Industry 4.0 demands comprehensive QoS capabilities

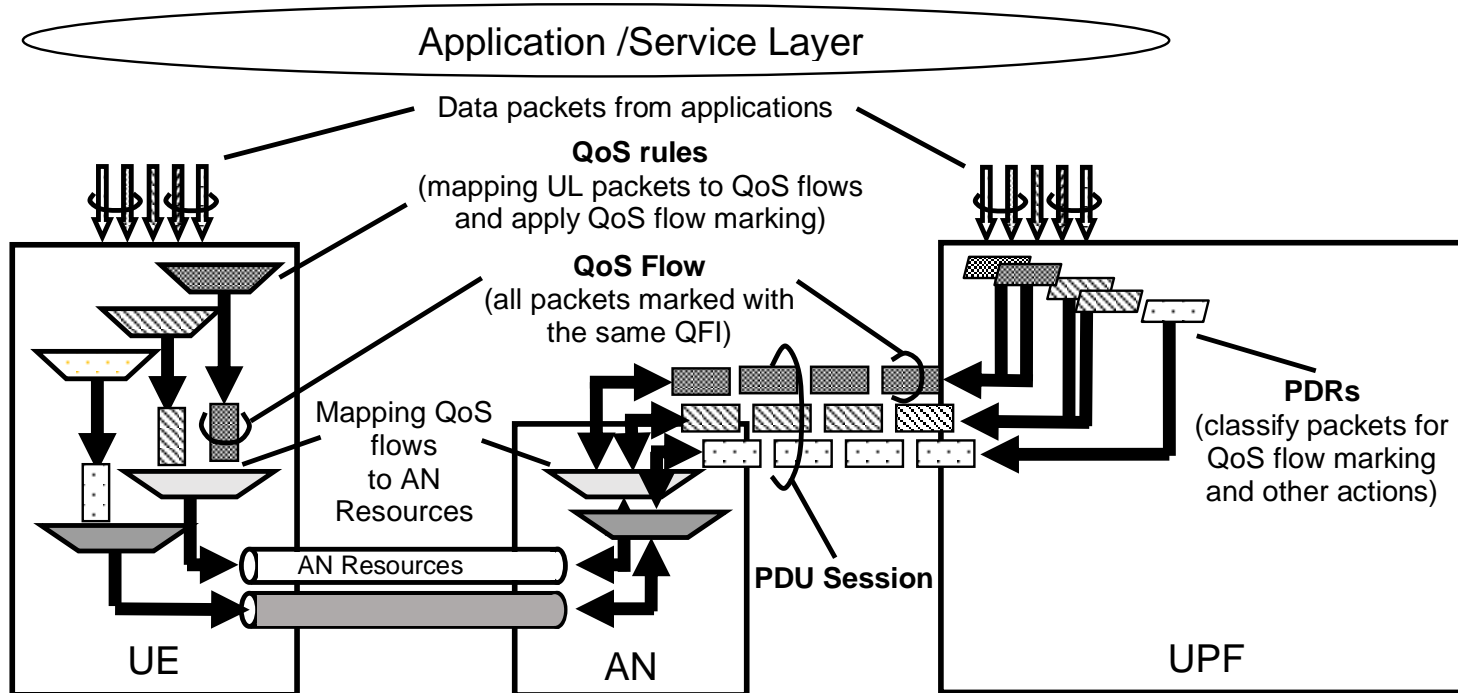

3GPP TS 23.501 Figure 5.7.1.5-1:
The principle for classification and User Plane marking for QoS Flows and mapping to AN Resources

5G QoS characteristics is defined through:

- Resource Type (GBR, Delay critical GBR or Non-GBR);
- Priority Level;
- Packet Delay Budget;
- Packet Error Rate;
- Averaging window (for GBR and Delay-critical GBR resource type only);
- Maximum Data Burst Volume (for Delay-critical GBR resource type only).

LiFi integration through adoption of 3GPP WLAN (Wi-Fi) integration model

Straightforward, but probably not really the desired solution

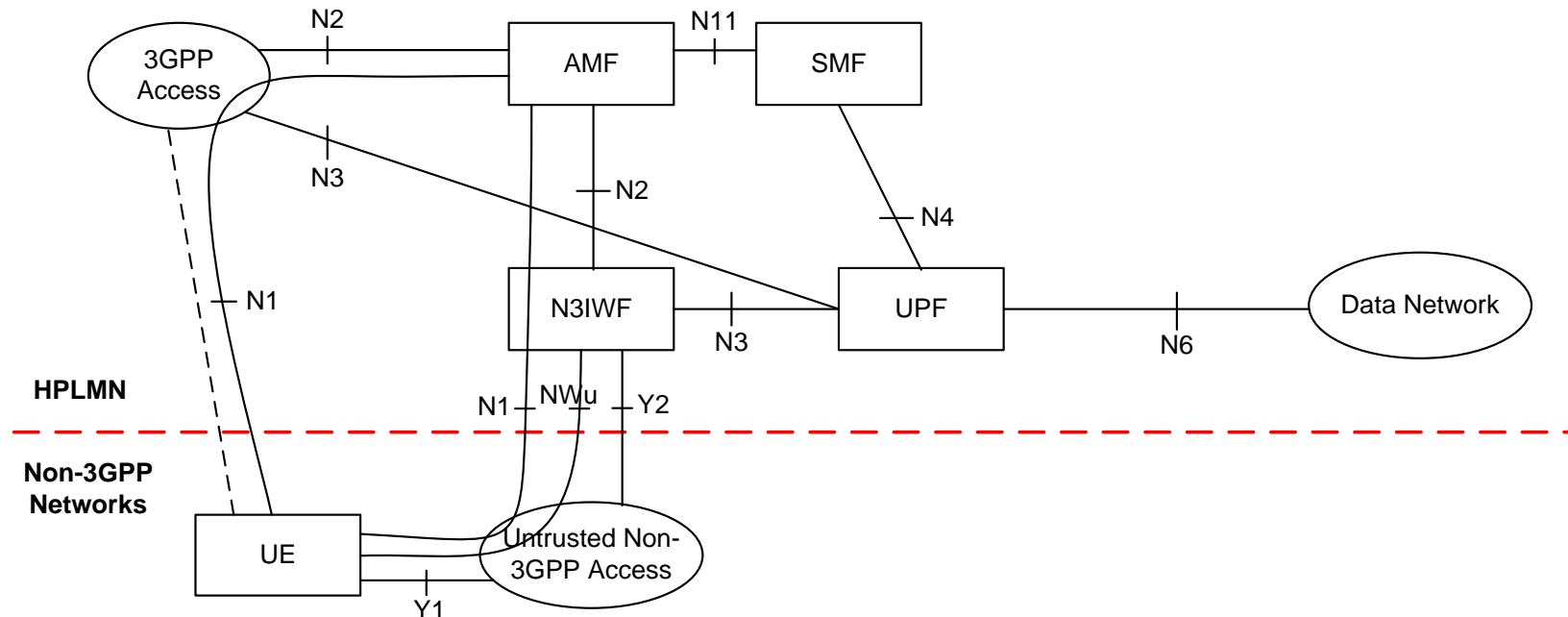

3GPP TS 23.501 Figure 4.2.8.2.1-1: Non-roaming architecture for 5G Core Network with untrusted non-3GPP access

- N3IWF gateway function propagates 5G data and control traffic through an IPsec tunnel (NWu) secured through IKEv2/EAP-AKA' between UE and 5G core.
- Fulfils all security requirements, however adds complexity, delay, and makes proper QoS handling tricky.

Issues of the 3GPP WLAN integration model for LiFi

LiFi isn't just another kind of Wi-Fi

- Wi-Fi provides huge transfer capacities for offloading bulk Internet data in the local area
 - Wi-Fi is treated as an auxiliary interface next to the 3GPP cellular radio interface
 - Usually dual-mode operation, no need for comprehensive QoS management
- LiFi introduces a new kind of transmission capabilities for wireless communications
 - No fallback/offload to 5G radio, mostly stationary due to very small cell sizes
 - Likely single mode LiFi only, with need for comprehensive QoS management

Issues of the 3GPP WLAN integration model for LiFi

LiFi isn't just another kind of Wi-Fi

- Wi-Fi provides huge transfer capacities for offloading bulk Internet data in the local area
 - Wi-Fi is treated as an auxiliary interface next to the 3GPP cellular radio interface
 - Usually dual-mode operation, no need for comprehensive QoS management
- LiFi introduces a new kind of transmission capabilities for wireless communications
 - No fallback/offload to 5G radio, mostly stationary due to very small cell sizes
 - Likely single mode LiFi only, with need for comprehensive QoS management
- Current Wi-Fi does not provide full support of 5G QoS model and control
 - Only a small subset of the 5G QoS classes can be supported
 - Signaling and secure transport is realized OTT through 5G-EAP/IKEv2/IPsec tunnel
- LiFi demands a 'better' integration model
 - Direct attachment, less protocol overhead, link layer integration

The 'better' integration model for LiFi

3GPP already provides the basic architectural hooks

- The Trusted WLAN Interworking Function (TWIF) provides interworking functionality that enables N5CW devices to access 5GC.
 - "Non-5G-Capable over WLAN" (N5CW) devices are not capable to provide 5GC NAS signaling over a WLAN access network.

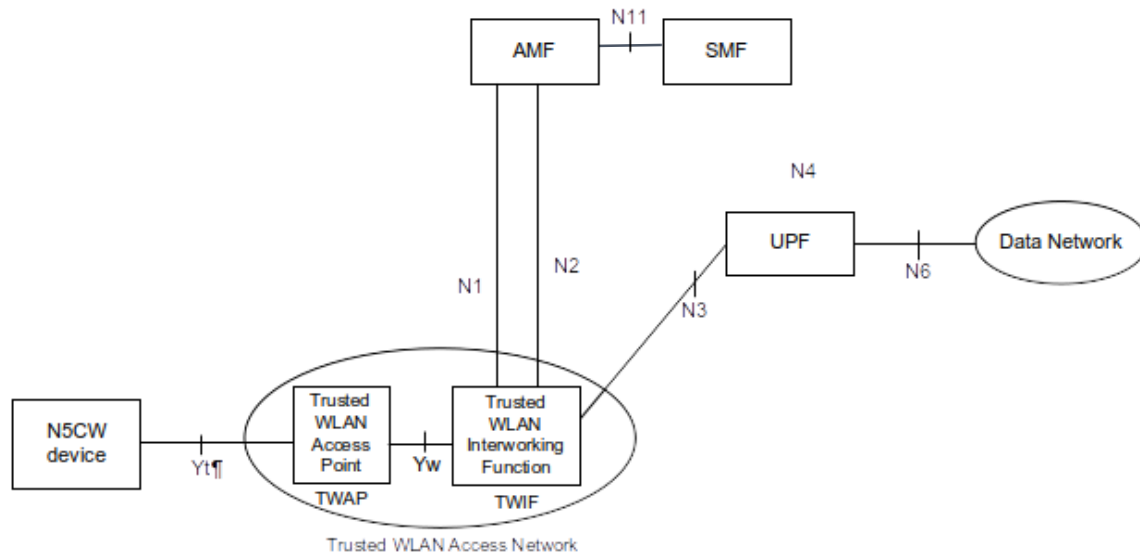

3GPP TS23.501 Figure 4.2.8.5.2-1: Non-roaming and LBO Roaming Architecture for supporting 5GC access from N5CW devices

The TWIF supports the following functions:

- Terminates the N1, N2 and N3 interfaces.
- Implements the AMF selection procedure.
- Implements the 3GPP NAS protocol stack for session and QoS control.
- Adapts the native user plane (link layer) of WLAN to the N3 interface.
- May implement a local mobility anchor within the trusted WLAN access network.

Summary and conclusion

- 5G fully serve the needs of Industry 4.0 for ultra-reliable low latency communications
- 5G provides excellent control and configuration capabilities for changing demands and environments
- But there is a gap between wired and wireless communication that could be filled through LiFi
- LiFi needs better integration with 5G system than available today for Wi-Fi
- Appropriate architectural model already available in 3GPP specification
- Further research and standardization needed to provide the missing pieces