

---

Self Organizing Networks

# WLAN IEEE 802.11 aka Wi-Fi

SS 2022 Electronic lecture – Part 2

Max Riegel

# SS2022 Lectures overview

---

- **June 2<sup>nd</sup>**
  - Wi-Fi applications and markets
  - Wi-Fi Spectrum
  - Wireless channel characteristics
  - Direct Sequence Spread Spectrum (initial Wi-Fi radio)
  - Orthogonal Frequency Division Multiplex
- **June 16<sup>th</sup>**
  - Wi-Fi 2 .. Wi-Fi 7 radios
  - Wi-Fi Standardization environment
- **June 23<sup>rd</sup>**
  - IEEE 802.11 architecture
  - Medium access functions
  - System management
- **June 30<sup>th</sup>**
  - MAC layer management
  - MAC layer frame formats
  - Quality of Service
- **July 7<sup>th</sup>**
  - Wi-Fi security
  - Mobility enhancements

---

WLAN IEEE 802.11 aka Wi-Fi

# **STANDARD REFERENCE**

# IEEE Std 802.11™-2020 + amendment 802.11ax™-2021



- Can be downloaded at no charge through the IEEE Get Program
  - <https://ieeexplore.ieee.org/browse/standards/get-program/page/series?id=68>
- No all the features specified in the standard are available in real Wi-Fi products
- This lecture presents behavior of real Wi-Fi products as specified by Wi-Fi Alliance in its certification programs
  - <https://www.wi-fi.org/discover-wi-fi/specifications>

## IEEE Standard for Information technology

### Part 11: Wireless LAN Medium Access Control (MAC) and Physical Layer (PHY) Specifications

- Revision of IEEE Std 802.11-2016
  - Revision of IEEE Std 802.11-2012
    - Revision of IEEE Std 802.11-2007
      - Revision of IEEE Std 802.11-1999
        - First IEEE 802.11 standard release in 1997
- Comprises initial IEEE Std 802.11-1999 and all amendments IEEE 802.11a-1999 ... IEEE 802.11aq-2018
  - i.e.: a, b, d, e, g, h, l, j, k, n, p, r, s, u, v, w, y, z, aa, ac, ad, ae, af, ah, ai, aj, ak, aq

## Amendment standard IEEE Std 802.11ax-2021

- Amendment 1: Enhancements for High-Efficiency WLAN

---

WLAN IEEE 802.11 aka Wi-Fi

# **IEEE 802.11 ARCHITECTURE**

# IEEE802.11 overview

---

- One common MAC supporting multiple PHYs
- CSMA/CA (collision avoidance) with optional “point coordination”
- Connectionless service
  - Transfer data on a shared medium without reservation
  - Data transmitted in bursts
  - Controlled through low-layer ACKs, so transmit at highest speed possible
  - Same service as used by Internet
- Robust against noise and interference (ACK)
- Hidden node problem (RTS/CTS)
- Power savings (Sleep intervals)
- Association, reassociation (handover capability)
- Security (WPA3)
- Two configurations
  - “Independent” (ad hoc) and “Infrastructure”

# IEEE 802.11 architecture

- 802.1X
  - Port Access Entity
  - Authenticator/Supplicant
- RSNA Key Management
  - Generation of Pair-wise and Group Keys
- Station Management Entity (SME)
  - interacts with both MAC and PHY Management
- MAC Sublayer Management Entity (MLME)
  - synchronization
  - power management
  - scanning
  - authentication
  - association
  - MAC configuration and monitoring
- MAC Sublayer
  - basic access mechanism
  - fragmentation
  - encryption
- PHY Sublayer Management Entity (PLME)
  - channel tuning
  - PHY configuration and monitoring
- Physical Sublayer Convergence Protocol (PLCP)
  - PHY-specific, supports common PHY SAP
  - provides Clear Channel Assessment signal (carrier sense)
- Physical Medium Dependent Sublayer (PMD)
  - modulation and encoding

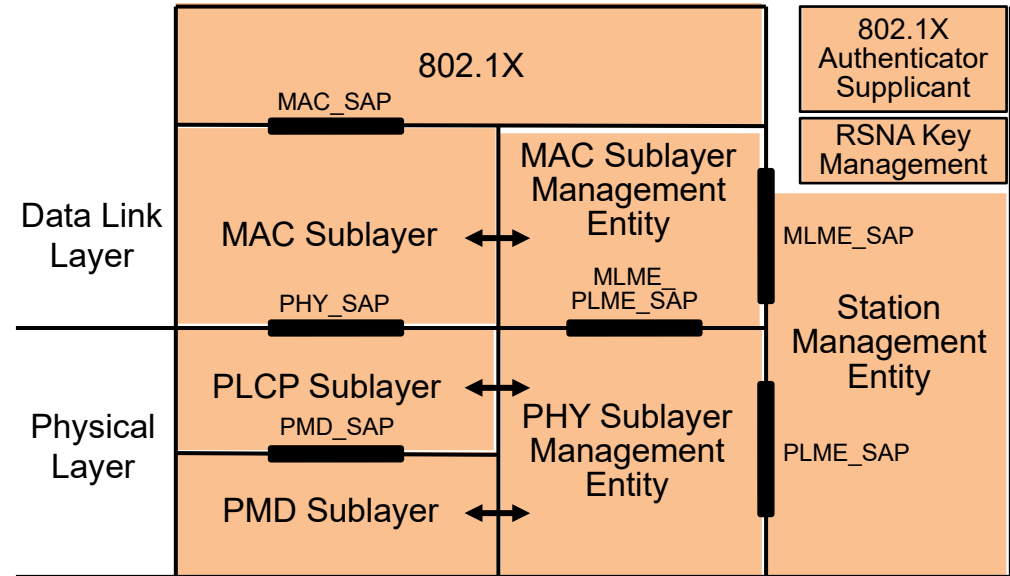

# IEEE 802.11 frame structure

- Each protocol layer deploys its own header for conveying the protocol information between peers

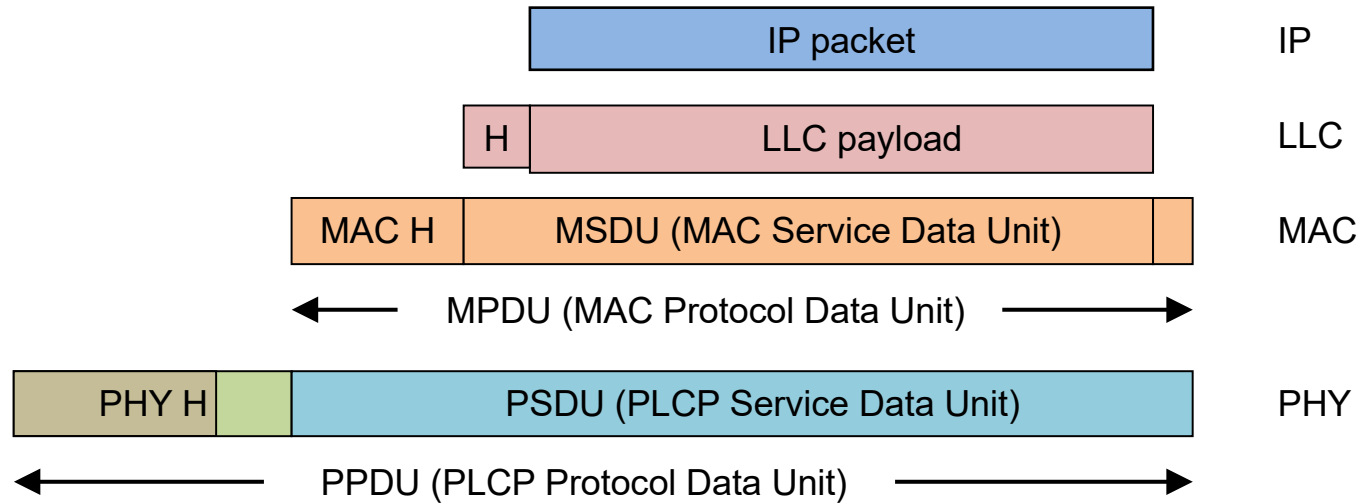

- IEEE 802.11 PHY header carries the information for setting up the reception of radio frames
- Physical Layer Convergence Protocol (PLCP) provides a PHY independent Service Access Point (SAP) for higher layers



---

WLAN IEEE 802.11 aka Wi-Fi

# **MEDIUM ACCESS FUNCTIONS**

# Medium Access Functions in IEEE802.11 architecture

- 802.1X
  - Port Access Entity
  - Authenticator/Supplicant
- RSNA Key Management
  - Generation of Pair-wise and Group Keys
- Station Management Entity (SME)
  - interacts with both MAC and PHY Management
- MAC Sublayer Management Entity (MLME)
  - synchronization
  - power management
  - scanning
  - authentication
  - association
  - MAC configuration and monitoring
- MAC Sublayer
  - basic access mechanism
  - fragmentation
  - encryption
- PHY Sublayer Management Entity (PLME)
  - channel tuning
  - PHY configuration and monitoring
- Physical Sublayer Convergence Protocol (PLCP)
  - PHY-specific, supports common PHY SAP
  - provides Clear Channel Assessment signal (carrier sense)
- Physical Medium Dependent Sublayer (PMD)
  - modulation and encoding

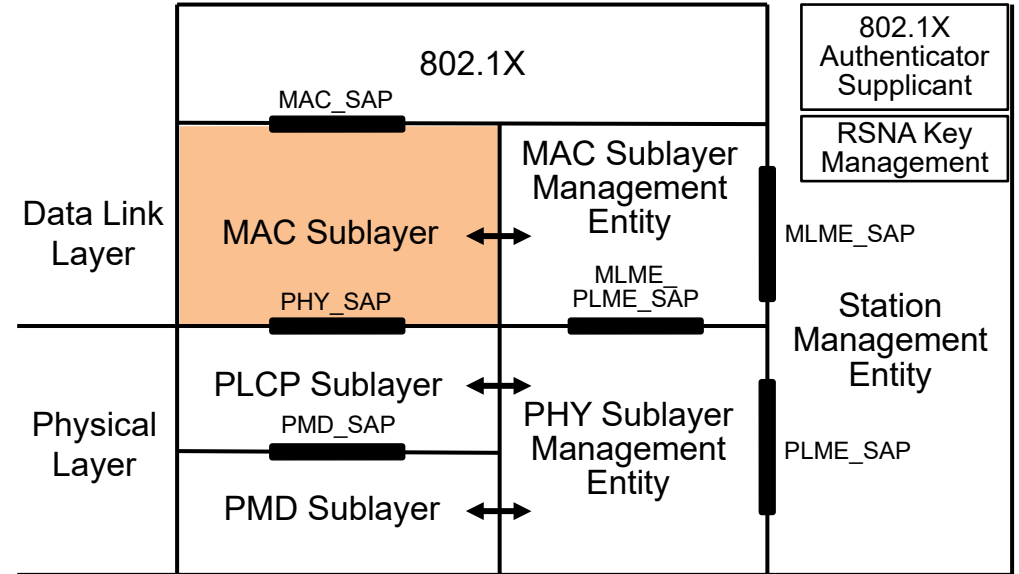

# Topics covered in this section

---

- Medium access functions
  - Challenges
  - CSMA/CA
  - Distributed Coordination Function
  - RTS/CTS
  - Hidden node treatment
  - Fragmentation

# Shared Spectrum Medium Access Challenges

- Multiple concurrent transmissions in the same channel might create collisions, which disallow to correctly receive the transmitted frames

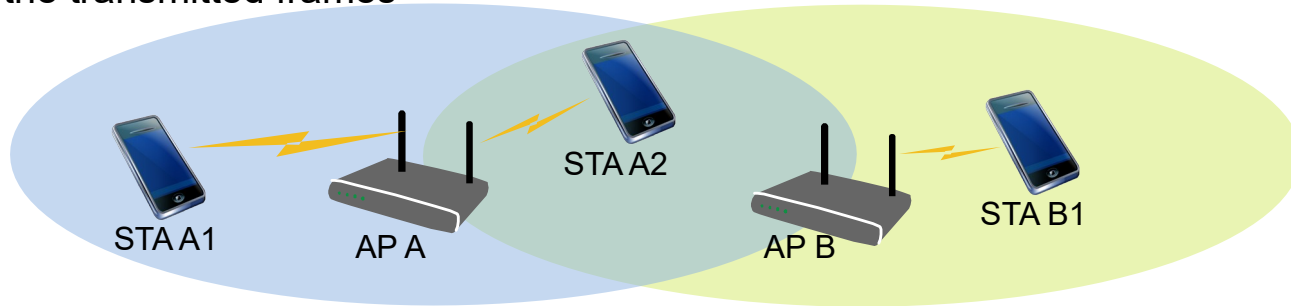

- No wireless issue only; same issue exists in shared wired medium as well
  - Ethernet introduced CSMA/CD (Carrier Sense Multiple Access/Collision Detection) to minimize impairments through collisions
  - CSMA denotes method that potential transmitters first listen to the medium to ensure that no other transmission is ongoing before starting own transmission
    - Same behaviour that humans are usually applying when talking with each other
  - Nevertheless, collisions occur through multiple transmitters waiting for the end of an ongoing transmission and starting their transmission right after.
    - Legacy Thin/Thick-wire Ethernet introduced Collision Detection with instantaneous stop and retrieval after some wait time – like humans;-).
- Wireless medium is somewhat more difficult
  - CSMA can be deployed the same way as on the shared wired medium
  - However, when transmission is ongoing, a station can't detect collisions occurring somewhere else in the shared domain
    - Transmitter learns about collisions only through missing acknowledgements from receiver
  - Randomized backoff when medium is becoming free is used to minimize collision probability (Collision Avoidance)

# Carrier Sense Multiple Access with Collision Avoidance (CSMA/CA)

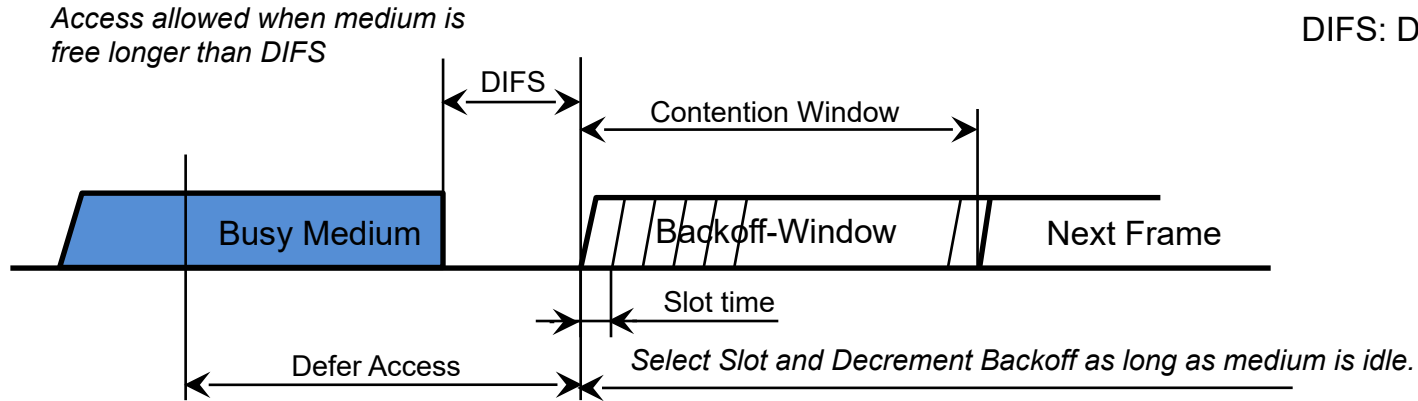

- Reduce collision probability where mostly needed.
  - Stations (also APs) are waiting for medium to become free.
  - Random backoff is used after a defer, resolving contention to avoid collisions.
    - Random backoff is an equally distributed value in the range  $0..CW_{min}$ ;  $CW_{min} = 15$
  - Exponential backoff is used in the case of retransmissions
    - $CW = (2^k - 1)$  with  $k = n + 4$  with  $n =$  number of retransmission;  $CW_{max} = 1023$
    - Efficient Backoff algorithm stable at high loads.
  - Backoff timer elapses only when medium is idle.

# Distributed Coordination Function (DCF): How CSMA/CA works ...

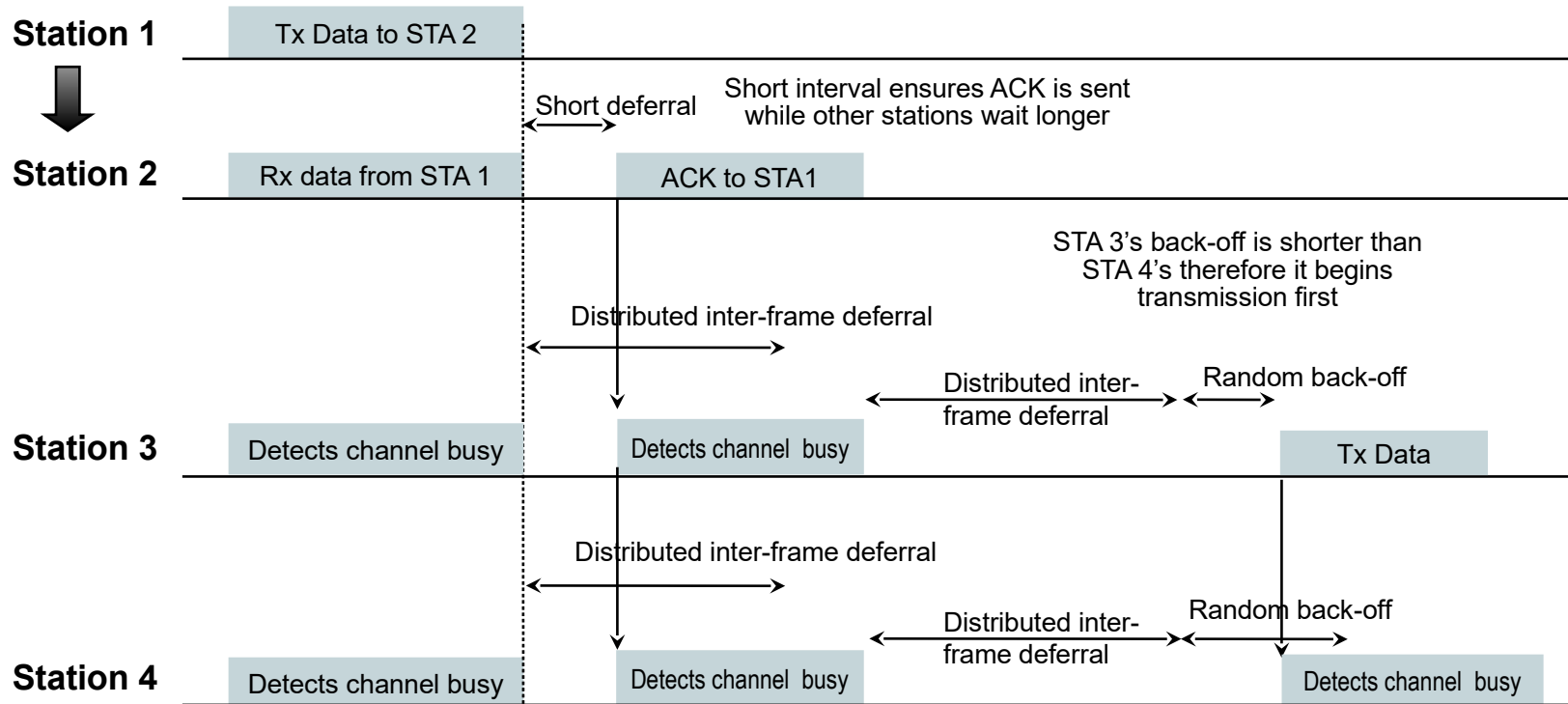

# Clear Channel Access (CCA): Determining that channel is empty

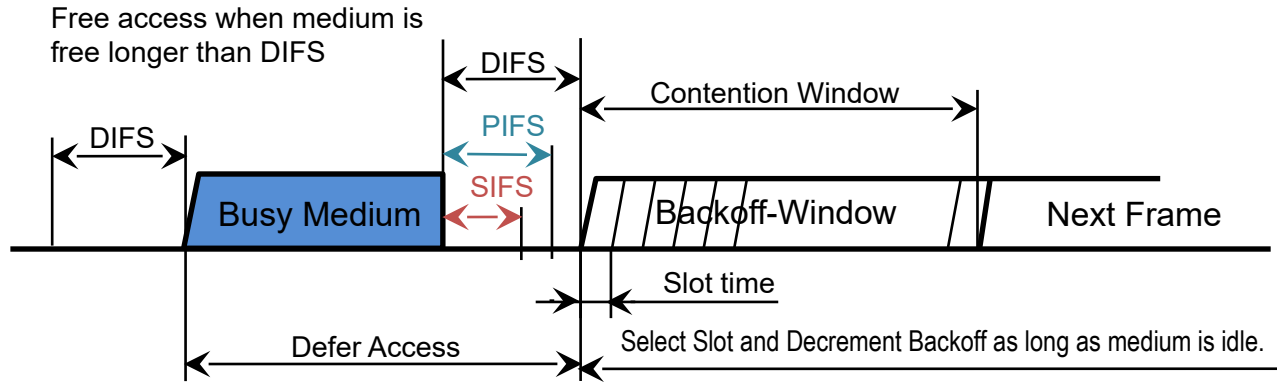

Standard	Slot time (µs)	DIFS (µs)
IEEE 802.11b	20	50
IEEE 802.11a/n/ac	9	34
IEEE 802.11g/n	9	28

SIFS: Short Inter Frame Space  
PIFS: PCF Inter Frame Space  
DIFS: DCF Inter Frame Space  
DIFS = SIFS + 2x Slot time

- Medium is sensed for becoming idle.
  - Random backoff is applied after DIFS to avoid collisions.
  - In the case of retransmissions exponential backoff is used to avoid collapse of the system.
- Two different thresholds are used for sensing in Wi-Fi
  - Regulatory requires that the medium has to be considered as occupied when an energy level higher than  $-62 \text{ dBm}/20\text{MHz}$  can be detected
  - For better coverage, Wi-Fi deploys a more sensitive detection of neighbour Wi-Fi systems through preamble detection at a level of  $-82 \text{ dBm}/20\text{MHz}$
- In addition to physical sensing there is also predictive signaling of medium occupancy through timer values.

# Spatial Reuse through BSS Coloring

- In dense deployments, CCA is often 'over-protective'
  - Transmissions are stalled due to activities at a distant AP operating in the same channel
  - A successful transmission could be performed in the local system due to proximity of STA and AP despite parallel activities in the distant system

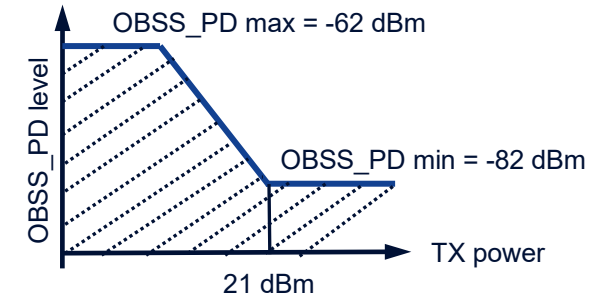
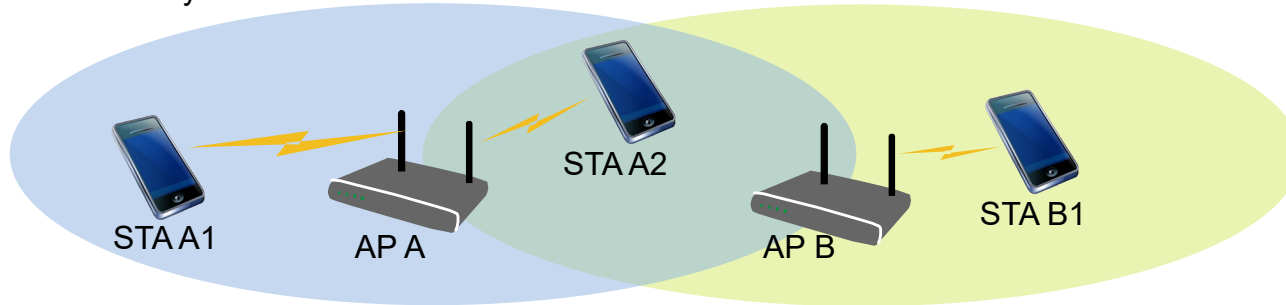

- Wi-Fi 6 introduces the possibility to determine intra-BSS frames from frames coming from other systems (OBSS)
  - Called 'BSS Coloring', which puts a color value into the PHY header of each transmission frame.
- In addition, assignments and detection of Spatial Reuse Groups (SRG) are possible to determine between devices under common management, and devices not under common control.
- According to detected interference levels, the preamble detection threshold of OBSS will be adjusted to allow for more aggressive spectrum reuse.
  - To mitigate negative side-effects also the transmission power of devices within a SRG is adjusted to lower overall interference level.



# Physical and virtual carrier sensing operation

- Defer access based on Carrier Sense.
  - Either physical through CCA (Clear Channel Assessment) from PHY
  - Or virtual carrier sense state through NAV (Network Allocation Vector)

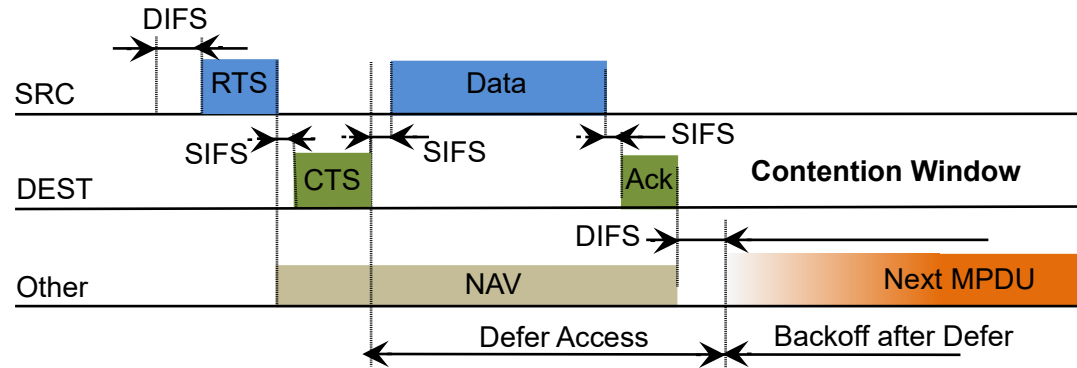

- Direct access when medium is sensed free longer than DIFS, otherwise defer and backoff.
- Receiver of directed frames return ACK immediately when CRC is correct.
  - When transmitter does not receive ACK then retransmission of frame is initiated after a random backoff

# Request-To-Send/Clear-To-Send (RTS/CTS)

- Used to handle congested/heavily loaded radio environment through control of AP

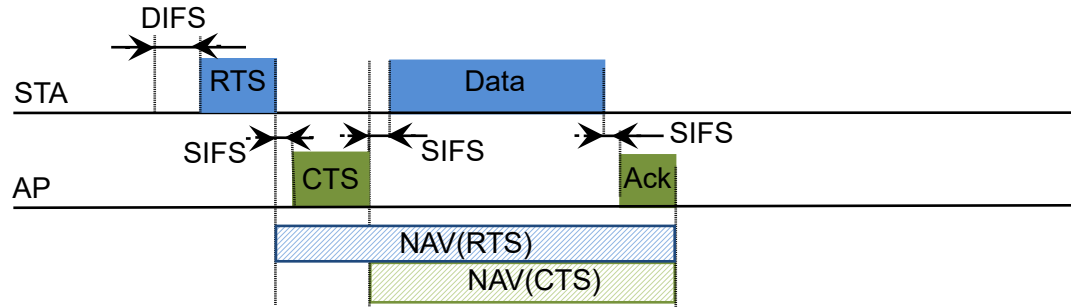

- STA sends a RTS frame to the AP with the amount of time stated in the NAV (Network Allocation Vector) to transmit its data frame including the ACK
  - NAV represents the overall transmission duration, i.e. the time needed for transmitting the data frame including the following ACK
- The AP acknowledges the medium reservation with a CTS frame, which contains the updated reservation time in the NAV
- STA might start transmitting its data when the CTS message arrives
- All stations monitor RTS/CTS frames and use the gathered information from the NAV to adjust their channel access procedure

# Hidden Node Problem

- Problem occurs when contending stations for the medium do not hear each other

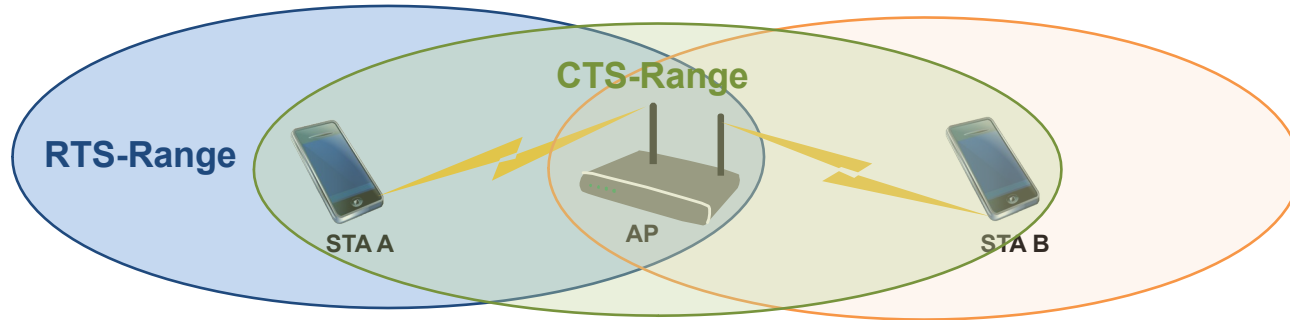

- STA-B cannot detect when STA-A occupies the medium.
- STA-B may interfere with transmissions of STA-A to the AP
- Without further measures the performance may be seriously impacted
- WLAN provides an mechanism to solve the hidden station problem:
  - Medium access control with RTS (Request To Send) and CTS (Clear To Send)

# Hidden Station Solution

- STA-A sends a RTS frame to the AP with the amount of time stated in the NAV (Network Allocation Vector) to transmit its data frame including the ACK
  - The AP acknowledges the medium reservation with a CTS frame, which contains the updated reservation time in the NAV
  - STA-A might start transmitting its data when the CTS message arrives
- All stations monitor RTS/CTS frames and use the gathered information from the NAV to adjust their channel access procedure
  - STA-B only starts its transmission after expiration of the NAV preferably with RTS to let AP inform hidden neighbors about ongoing transmission.

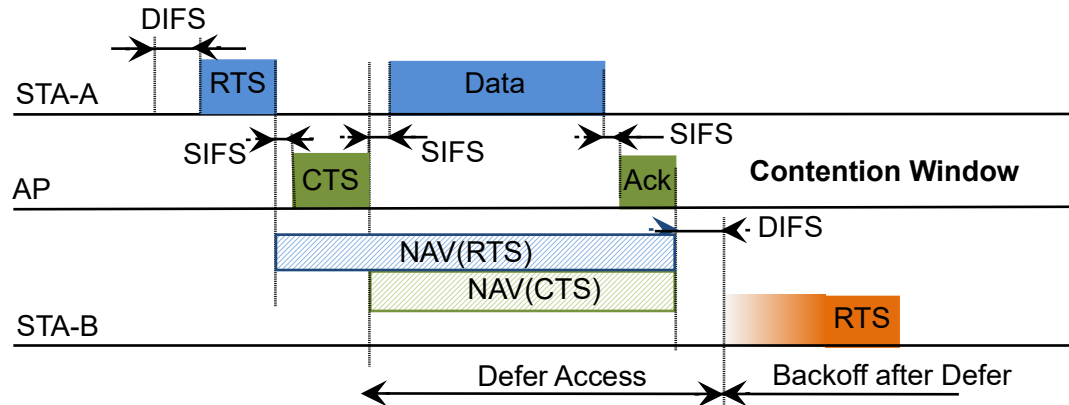

# Fragmentation

- Packet loss probability increases when data packets are becoming big in a noisy environment
- Limiting the maximum packet size reduces the probability that a packet is hit by a bit failure.
- The MAC Layer provides the function to split packets into multiple smaller frames for transmission

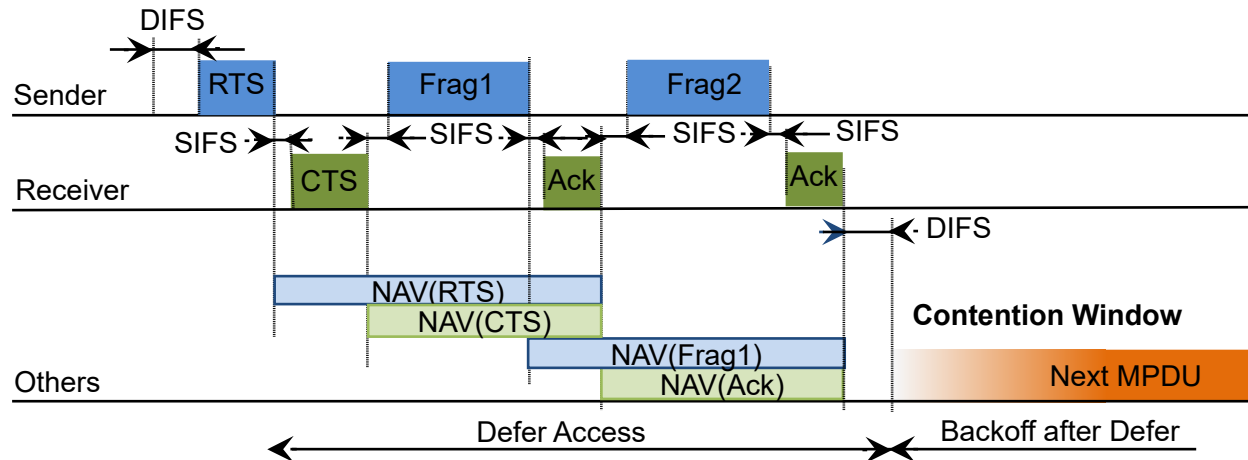

# Summary: IEEE 802.11 basic access protocol features

---

- Efficient medium sharing through CSMA with enhancements for access control.
  - Access procedure denoted as ‘Distributed Coordination Function (DCF)’
  - Use of CSMA with Collision Avoidance through randomized delays.
  - Based on Carrier Sensing function in PHY called ‘Clear Channel Assessment (CCA)’.
  - Robust against high overload through exponential backoff in case of access collisions.
- Robust against interference and noisy channels.
  - CSMA/CA + ACK for unicast frames, with MAC level recovery to avoid negative impact to TCP/IP.
  - CSMA/CA for Broadcast frames.
- Parameterized use of RTS / CTS to provide a Virtual Carrier Sense function to protect against Hidden Nodes.
  - Duration information is distributed by both transmitter and receiver through separate RTS and CTS Control Frames.
- Includes fragmentation to cope with various PHY conditions and longer frame sizes.

# Questions and answers

---



# Medium Access Functions questions...

---

- 1) Why does collision detection with immediate termination of transmission usually not work in wireless medium?
- 2) What means are used by IEEE 802.11 to avoid collisions?
- 3) What does SIFS mean, and for which frame is it used?
- 4) What is the difference between random backoff and exponential backoff?
- 5) How is virtual carrier sensing done?
- 6) When does a receiver respond with an ACK to a received frame?
- 7) What is the issue of the hidden station problem?
- 8) Which procedure is used to mitigate the hidden station problem?
- 9) Which message is used by a receiver to respond to a 'Request To Send'?
- 10) When is it beneficial to fragment the transmission of a long frame?



---

WLAN IEEE 802.11 aka Wi-Fi

# MAC LAYER MANAGEMENT

# MAC layer management in IEEE802.1 architecture

- 802.1X
  - Port Access Entity
  - Authenticator/Supplicant
- RSNA Key Management
  - Generation of Pair-wise and Group Keys
- Station Management Entity (SME)
  - interacts with both MAC and PHY Management
- MAC Sublayer Management Entity (MLME)
  - synchronization
  - power management
  - scanning
  - authentication
  - association
  - MAC configuration and monitoring
- MAC Sublayer
  - basic access mechanism
  - fragmentation
  - encryption
- PHY Sublayer Management Entity (PLME)
  - channel tuning
  - PHY configuration and monitoring
- Physical Sublayer Convergence Protocol (PLCP)
  - PHY-specific, supports common PHY SAP
  - provides Clear Channel Assessment signal (carrier sense)
- Physical Medium Dependent Sublayer (PMD)
  - modulation and encoding

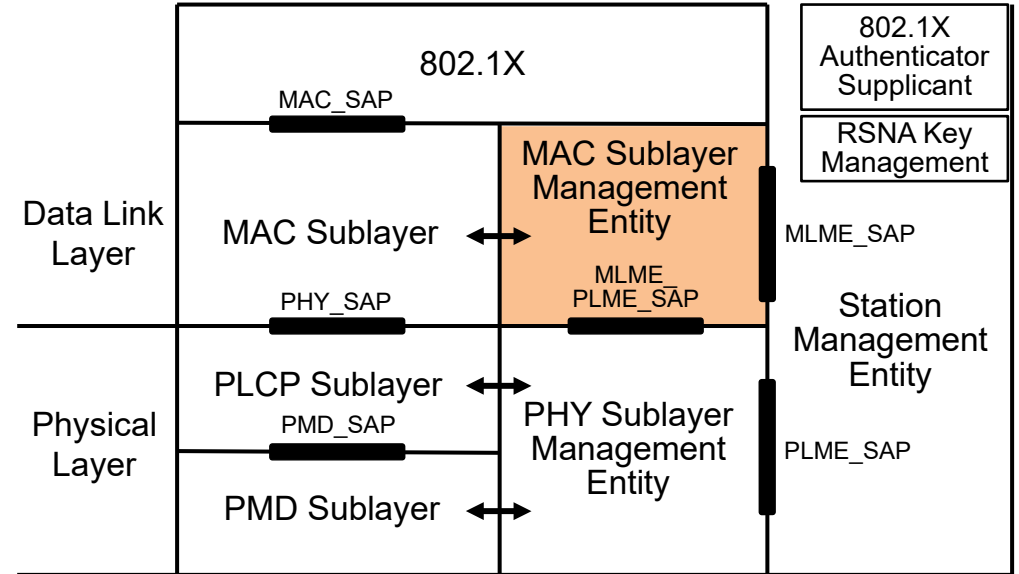

# Topics covered in this section

---

- MAC layer management
  - System management
    - Timer synchronization function
    - Power management
  - Session management
    - Session establishment
    - Scanning
    - Network selection
    - Authentication
    - Association
    - Mobility support
    - Message attributes

---

WLAN IEEE 802.11 aka Wi-Fi

# **SYSTEM MANAGEMENT**

# System Management - Overview

---

- Basic configurations
- Synchronization
  - Synchronization (Timer Synchronization Function)
    - Synchronization of timers of STAs and APs
  - Beacon generation
- Power management
  - Legacy power management
    - Support of periodic sleep of STAs with power save mode
      - Buffering of downstream MAC frames in the AP
      - Indication of pending traffic by Traffic Indication Map in Beacon
  - Target Wake Time (TWT)
    - Each STA negotiates its own TRX periods
  - Enhanced power management procedures

# IEEE 802.11 basic configurations

- Independent
  - one “Basic Service Set”, BSS
  - “Ad Hoc” network
  - direct communication
  - limited coverage area
- Infrastructure
  - Access Points and Stations
  - Distribution System interconnects Multiple Cells via Access Points to form a single Network.
    - extends wireless coverage area

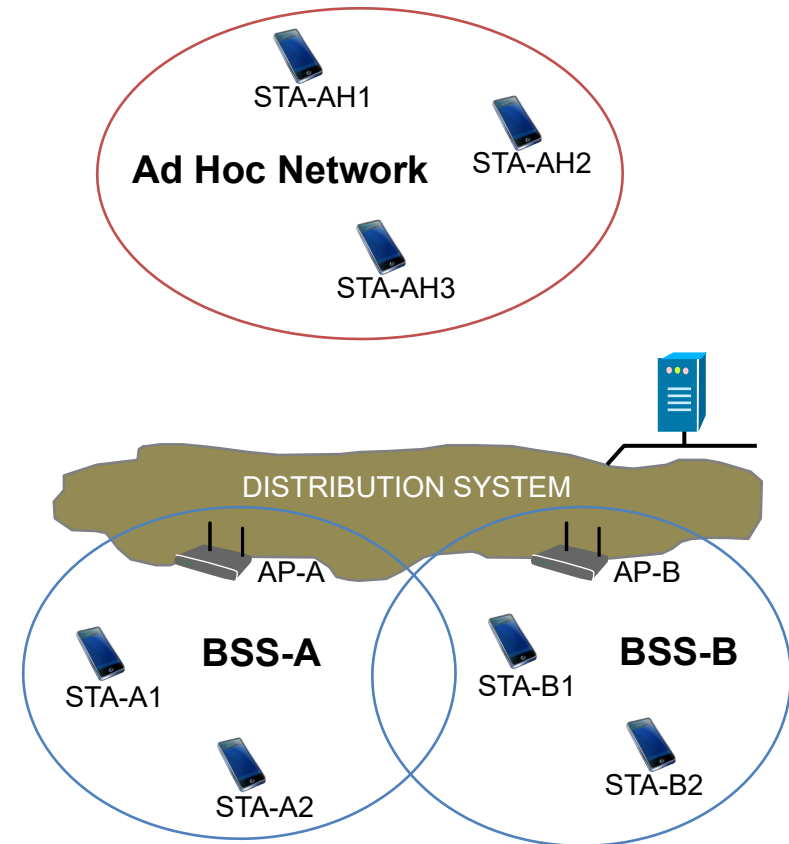

# Timing Synchronization Function (TSF)

---

- All STAs maintain a local timer.
  - Used e.g. for NAV, Power Management and other purposes
    - All station timers in BSS are synchronized
- Timing Synchronization Function (TSF)
  - Keeps timers from all STAs in synch
  - AP controls timing in infrastructure networks
  - For IBSS realized by distributed procedure
- Timing conveyed by periodic Beacon transmissions
  - Beacons contain Timestamp for the entire BSS
  - Timestamp from Beacons used to calibrate local clocks
    - Not required to hear every Beacon to stay in synch

# Infrastructure Beacon generation

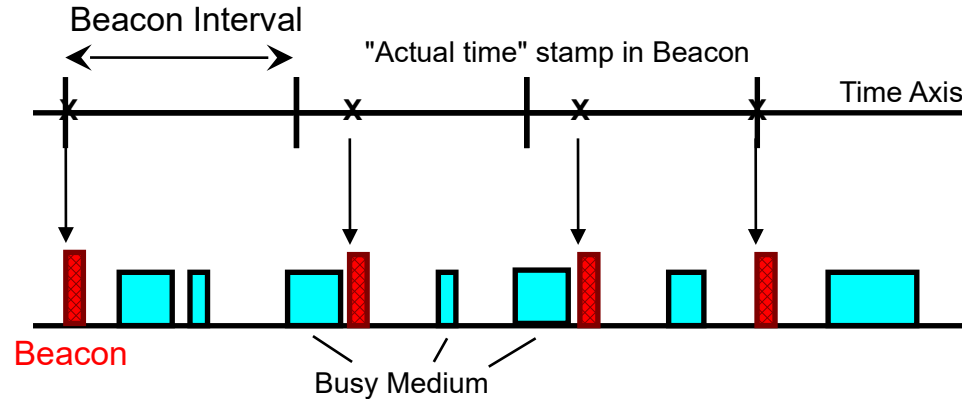

- APs send Beacons in infrastructure networks
  - Beacon is a broadcast frame recurrently send out at Beacon intervals
    - Beacon interval usually about every 100ms
  - Beacon contains SSID and further information about the functions offered by the AP
- Transmission may be delayed by CSMA deferral.
  - Subsequent transmissions at expected Beacon Interval
    - not relative to last Beacon transmission
    - next Beacon sent at Target Beacon Transmission Time
- Timestamp contains timer value at transmit time.



# Legacy Power Management Procedure

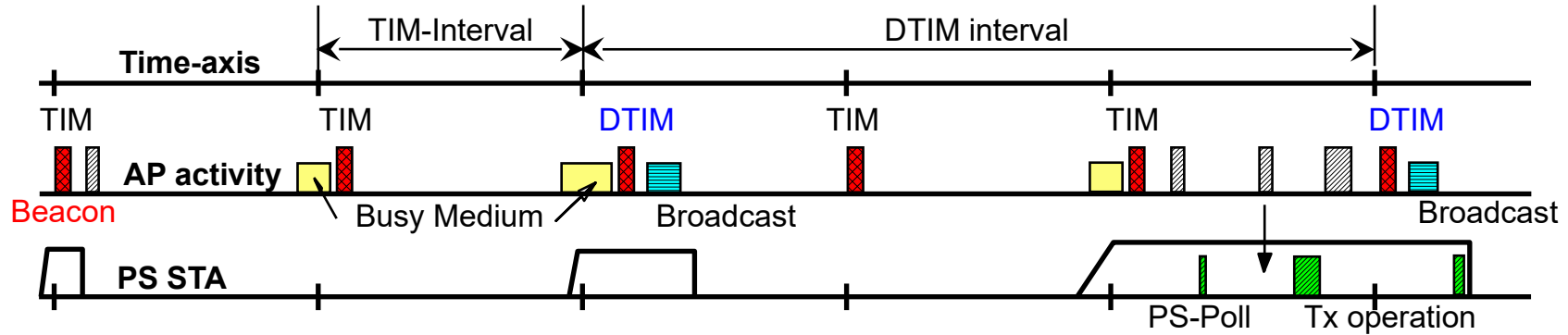

- APs send periodic Beacons and operates as proxy for 'sleeping' Stations
  - Beacon is a broadcast frame recurrently send out at Beacon intervals, usually about every 100ms containing SSID and further information about the the AP
  - AP buffers frames destined for sleeping stations and indicates availability of buffered frames in the Traffic Indication Map (TIM)
  - Associated Stations can register at AP that they will go into a Power-Save mode disabling even their receivers for most of the time
- STAs have to at least wake up shortly prior to an expected DTIM (Delivery Traffic Indication Map)
  - DTIM interval: interval at which buffered broadcast/multicast frames are transmitted
- If TIM indicates frame buffered for particular STA,
  - STA sends PS-Poll and stays awake to receive data
  - Else STA goes back to Power-Save state

# Target Wake Time (TWT) power save procedure

- Initially introduced through IEEE 802.11ah (HaLow)
- STAs that expect to sleep for long periods of time can negotiate a TWT contract with the AP.
- The AP stores any traffic destined for the STA until the TWT is reached.
- When the STA wakes at the prescribed time, it listens for its beacon and engages the AP to receive and transmit any data required before returning to its sleep state.
- The interval between TWT wake times can be very short (microseconds) to very long (years).

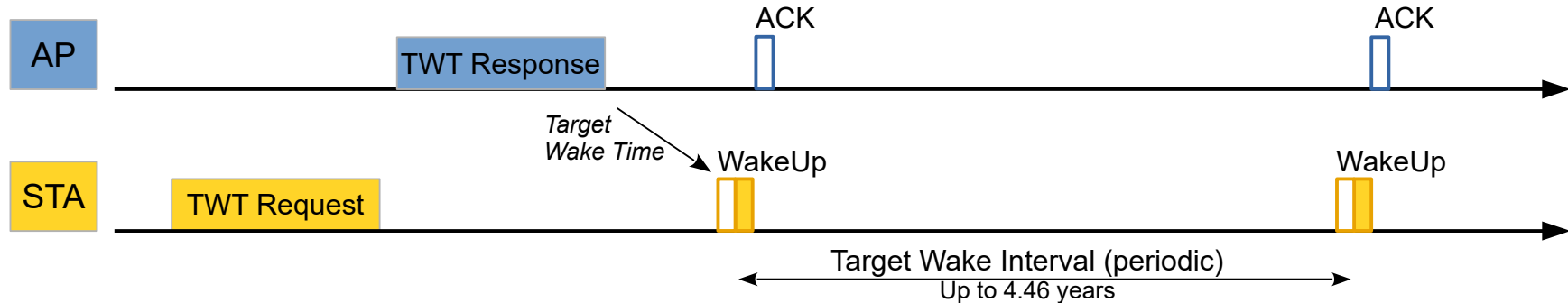

- **Benefits of predefined TRX time**
  - Wake-up time and channel access spread out
  - Allows AP to minimize contention
  - Reduces awake time for STAs, especially non-TIM STAs

# Enhanced Power Management Procedures

Power Save Feature	How does it work?
Unscheduled Asynchronous Power Save Delivery (U-APSD)	Allows a STA to retrieve unicast QoS traffic buffered in the AP within one TXOP by sending trigger frames.
Target Wake Time (TWT)	Allows a STA to stay asleep for (long) periods of time and wake up at timeslots that are pre-scheduled (targeted) with the AP.
Restricted Access Window (RAW)	During a 'RAW' only a pre-defined subset of STAs are allowed to conduct uplink transmissions. This can reduce power consumption due to reduced contention for the medium.
Extended Max Idle Period	Extends the period during which a STA is allowed to be asleep before the AP disregards the STA. Theoretical maximum period is over 5 years, in practice this will be implementation dependent.
Hierarchical TIM	Method to more efficiently encode the Traffic Indication Map to reduce the 'on air time' for the TIM and to accommodate large number of STAs per AP.
Non-TIM Operation	Removes the need for a STA to periodically wake up to check beacon messages. In addition, the TIM part of the beacon can be ignored, when receiving a beacon.

# Questions and answers

---



# System management Questions...

---

- 1) What does MLME stand for?
- 2) Which sublayer provides the convergence protocol between the PMD Sublayer and the MAC sublayer in the protocol architecture?
- 3) What function provides the Distribution System of the Infrastructure configuration?
- 4) What are the two main functions of the MAC layer systems management?
- 5) What is the purpose of the Timer Synchronization Function?
- 6) Please shortly outline the role of the Delivery Traffic Indication Message for the power management in IEEE 802.11
- 7) What does TWT mean, and by which method does it provides better power management than legacy TIM?

---

WLAN IEEE 802.11 aka Wi-Fi

# **SESSION MANAGEMENT**

# Session Management - Overview

---

- Scanning for available networks and mode of attachments
  - Beaconing
  - Active/passive scanning
- Network selection
  - Generic Advertisement Service
    - Pre-association information query
- Authentication
- Association/Disassociation/Re-association
  - Association: Joining a WLAN network
    - Session establishment
  - Disassociation: Detaching from an AP
    - Session termination
  - Re-association: Transfer of connectivity from one AP to another AP
    - Mobility management

# IEEE 802.11 session establishment

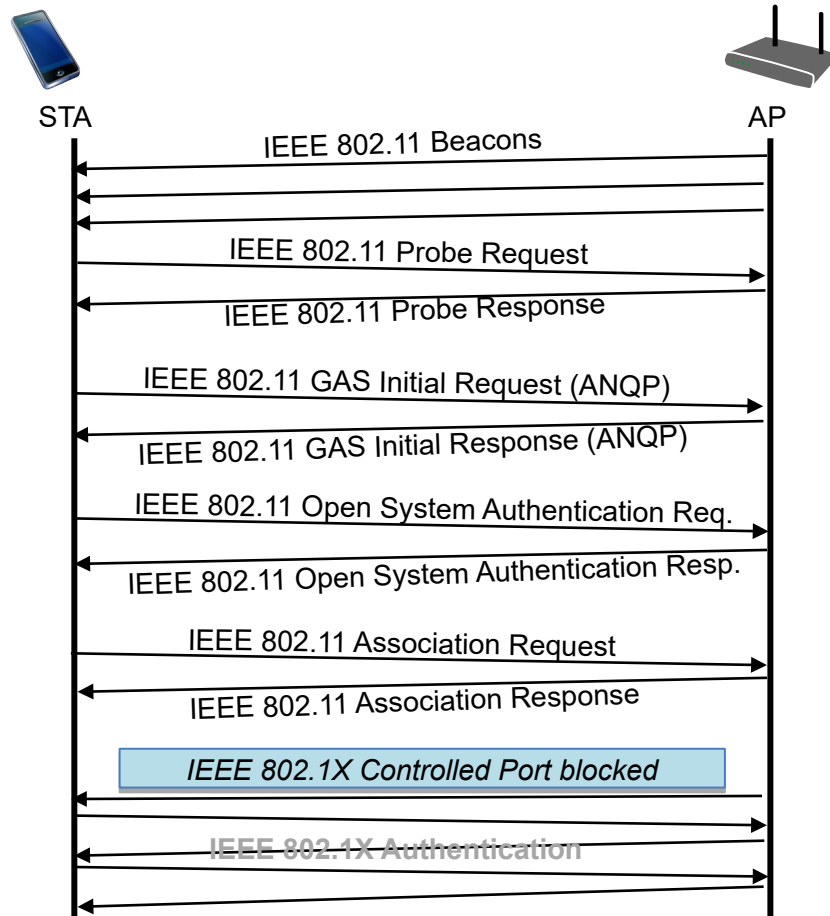

- Scanning
  - Beacon
  - Probe Request/Response
- Network Selection
  - GAS (ANQP Request/Response)
- Authentication
  - For legacy reasons OpenSystem Authentication Request/Response retained
    - Initially no use of IEEE 802.1X
- Association
  - Association Request/Response
- 802.1X Authentication/Authorization
  - IEEE 802.1X EAPoL follows association message exchange
    - Controlled port blocked
    - Uncontrolled port used for exchange of authentication messages
  - Authorization provided by AAA server to AP for configuration of data path



---

Session Management

# SCANNING

# Scanning

---

- Scanning is process of finding available APs and WLANs
  - WLANs identified by Service Set Identifier (SSID)
    - SSID is an arbitrary human readable network name with up to 32 ASCII characters
    - All APs of a WLAN (= Extended Service Set) have the same SSID
      - SSIDs are not necessarily unique
    - To enable unique WLAN names, SSID can be amended by Homogeneous Extended Service Set Identifier (HESSID)
      - HESSID is a MAC address (BSSID) of one of the APs of the ESS
  - APs identified by Basic Service Set Identifier (BSSID)
    - BSSID is the MAC address used in the radio transmission frames as AP address
- WLAN identification information can be detected
  - Either by decoding information carried in the Beacons
    - Passive Scanning
  - Or by sending out broadcast frames querying responses with WLAN identification information from adjacent Aps
    - Active Scanning

# Passive scanning

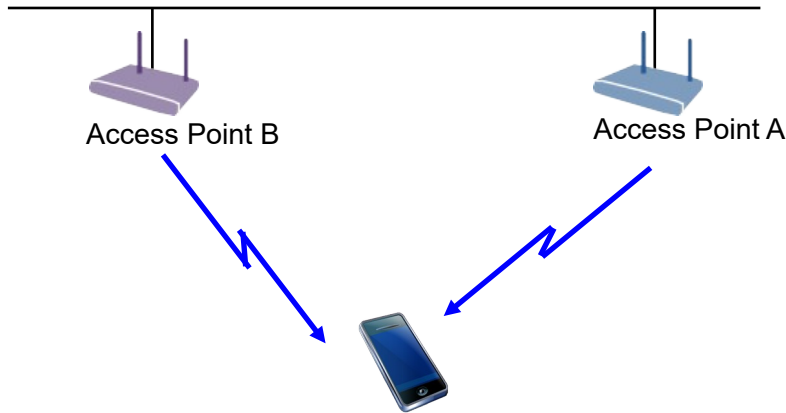

- APs send Beacons every 100..200ms
- STA subsequently tunes to all channels and listens for Beacons
- To successfully detect all Beacons, STA stays on a channel for about 200-300ms
- Scan of 2.4 GHz band takes about 2.5-4 s

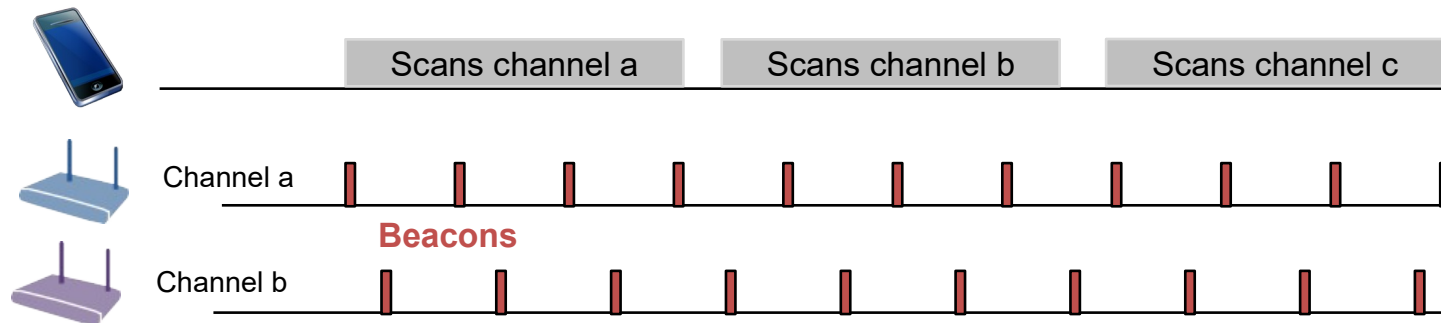

# Active scanning

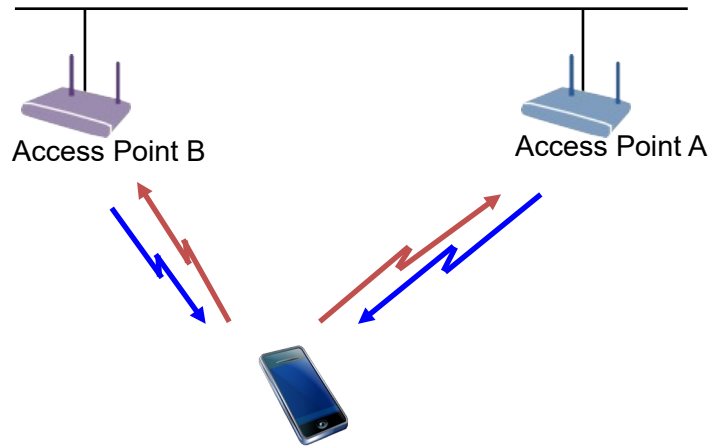
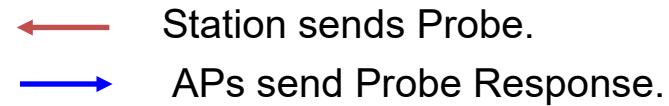

- STA tunes to all channels and sends Probe Requests.
- APs respond within a few ms.
- Query can either be directed to a particular WLAN or can send to all WLAN to respond.
- Even when transmitter is engaged in STA, active scanning is often more power effective.

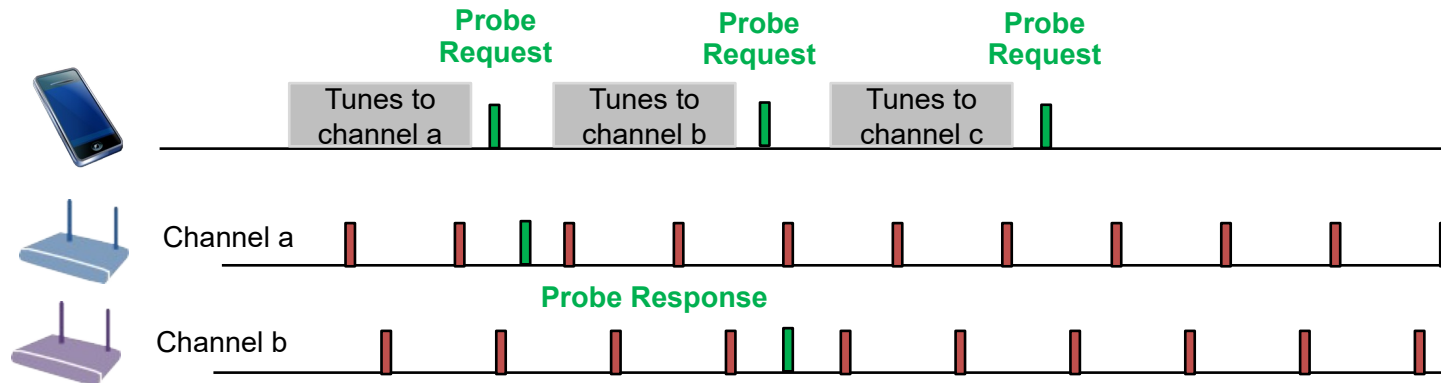

---

Session Management

# **NETWORK SELECTION**

# Generic Advertisement Service

---

- A Wi-Fi terminal scans the air for finding the near-by access points
  - Either by passive scanning (Beacon)
  - or by active scanning (Probe Request & Probe Response)
- Questions arising when discovering an access point:



- *Is this my Home Service Provider?*
- *Is this a Visited Service Provider?*
- *Will this Service Provider offer the services I need?*
- *Do I need any provisioning for this Service Provider?*

- The information in the beacon or probe response is often not sufficient to make the appropriate decision
- Introduced by 802.11u, IEEE 802.11 defines a protocol allowing to query additional information about the Wi-Fi access before initiating the association and authentication
- GAS (Generic Advertisement Service) provides a container for the ANQP (Access Network Query Protocol), which provides more information about the Wi-Fi access

# Network discovery by ANQP

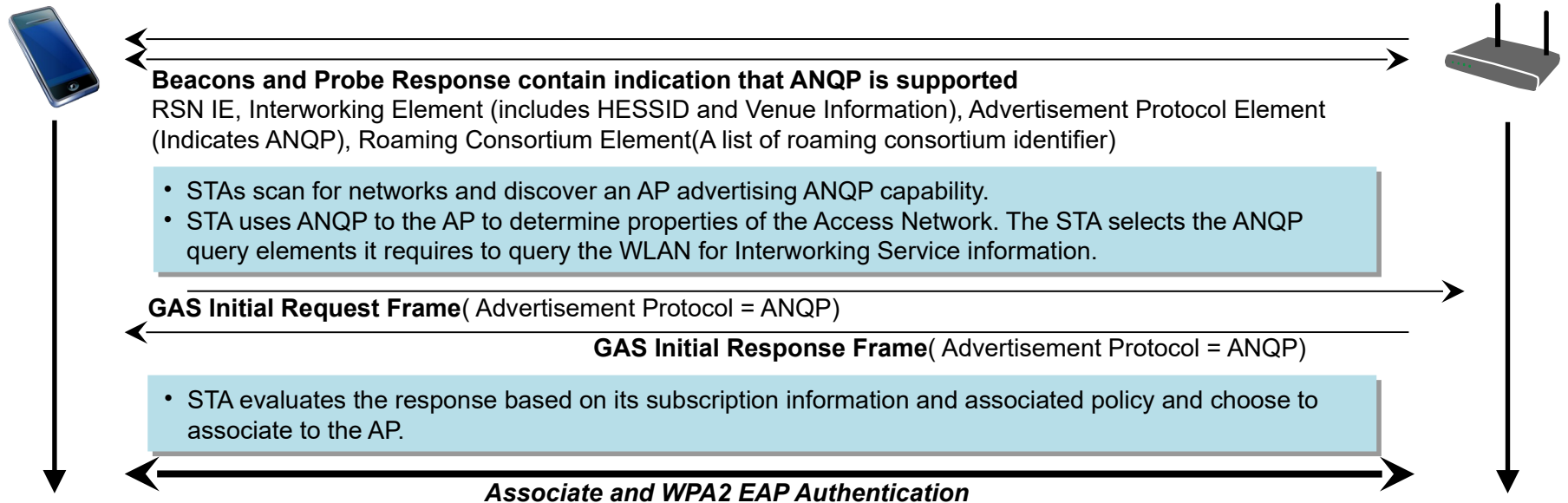

## ANQP Attributes

- Venue Name
- Network Authentication Type
- Roaming Consortium
- IP Address Type Availability
- NAI Realm
- 3GPP Cellular Network
- Domain Name

# ANQP Attributes

---

- Venue Name
  - Provides zero or more venue names associated with the BSS to support the user's selection.
- Network Authentication Type
  - Provides a list of authentication types carrying additional information like support for online enrollment or redirection URL.
- Roaming Consortium
  - Provides a list of information about the Roaming Consortium or Subscription Service Providers (SSPs) whose networks are accessible via this AP.
- IP Address Type Availability
  - Provides STA with the information about the availability of IP address version and type that could be allocated to the STA after successful association.
- NAI Realm
  - Provides a list of Network Access Identifier (NAI) realms corresponding to SSPs or other entities whose networks or services are accessible via this AP; optionally amended by the list of EAP Method, which are supported by the SSPs.
- 3GPP Cellular Network
  - Contains cellular information such as network advertisement information e.g., network codes and country codes to assist a 3GPP non-AP STA in selecting an AP to access 3GPP networks.
- Domain Name
  - Provides a list of one or more domain names of the entity operating the IEEE 802.11 access network.



---

Session Management

# AUTHENTICATION

# Authentication

---

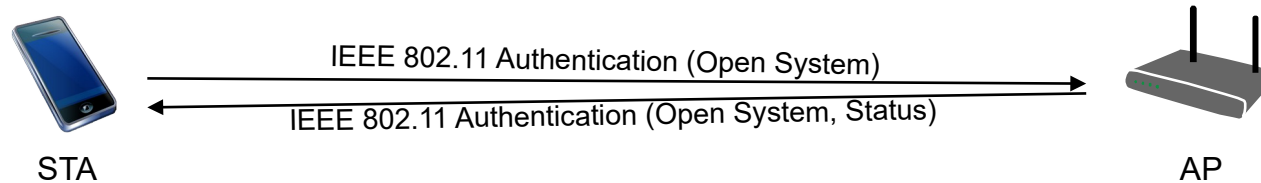

- Authentication before association is ‘leftover’ of legacy IEEE Std 802.11 without WPA2 support (prior to IEEE 802.11i aka WPA2).
- For conformance and compatibility reasons Open System Authentication is performed, which only checks for the MAC addresses of the STA.
  - In legacy IEEE 802.11, AP could authenticate STA by its WEP (Wire Equivalent Privacy).
    - WEP is depreciated now.
- Open System Authentication is the only check performed in unencrypted WLAN
  - MAC address authentication is often used to bypass captive portal in public access for ‘known’ users.
- Other methods for pre-association authentication can be used for Fast Transition (FT Authentication) and Mesh Networking (simultaneous authentication under equals (SAE)).

---

Session Management

# **ASSOCIATION**

# Association

---

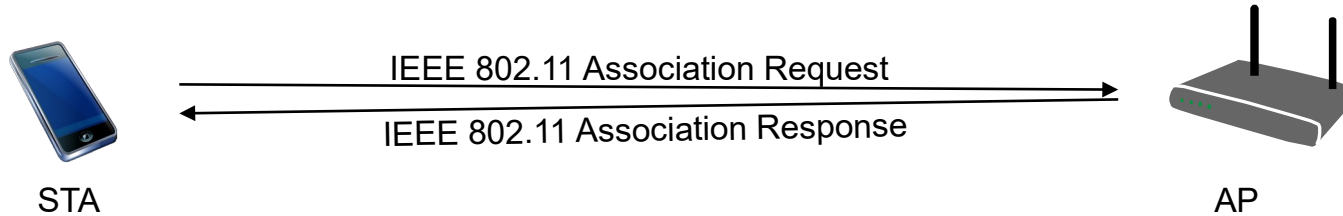

- Association establishes the data connection at the AP by assigning a virtual port for the STA
  - The STA sends an Association Request message containing its Listen Interval, various capabilities, the SSID to join and the supported transmission rates.
  - The AP checks for the acceptance of the parameters send in the Association Request frame and sends back an Association Response message, which contains an Association ID (AID), which allows unique identification of a station at the AP
    - AIDs are also needed for power management
- Once virtual port is available, Ethernet frames can be exchanged between STA and AP

# Message sequence for successful association

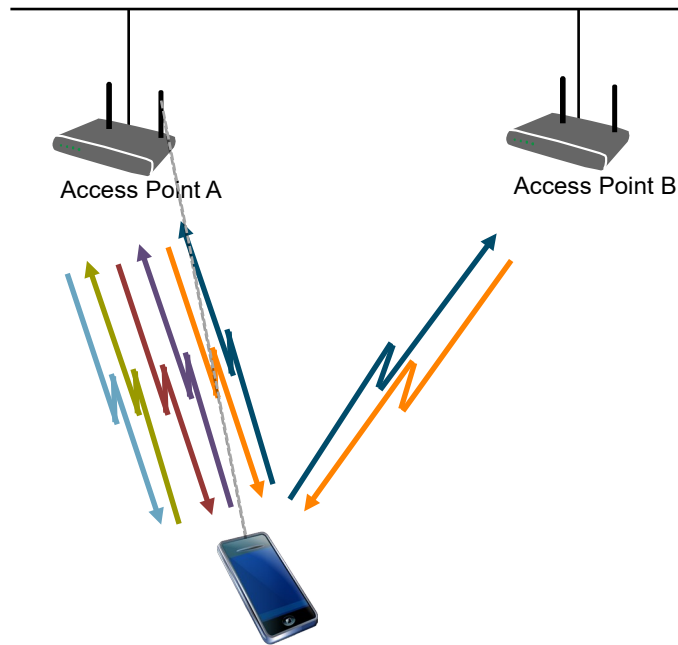

## Association with active scanning but without network selection by ANQP

Details:

- ← Station sends Probe Request
- APs send Probe Response  
=> Station chooses best AP
- ← Station sends Authentication Request to the chosen AP
- AP sends Authentication Response (success)
- ← STA sends Association Request to the chosen AP
- AP sends Association Response (success)

# Disassociation, Re-association

---

- Disassociation
  - Frame containing a reason code for termination of an association
- Re-association
  - Special form of Association procedure to support reconnection to another AP of the same ESS
  - Request frame additionally contains BSSID of previous AP
    - Allows new AP to contact previous AP for transfer of previous session info and pending data frames
  - Re-association is used for realizing ‘mobility’ in IEEE 802.11 within the same ESS (SSID).

---

Session Management

# **MOBILITY SUPPORT**

# Mobility inside an ESS by link layer functions

Station decides that link to its current AP is poor...

- **Station uses scanning function to find another AP**
  - or uses information from previous scans
- **Station sends Re-association Request to new AP**
- **If Re-association Response is successful**
  - then station has roamed to the new AP
  - else station scans for another AP
- **If AP accepts Re-association Request**
  - Normally old AP is notified through Distribution System
  - AP indicates Re-association to the Distribution System

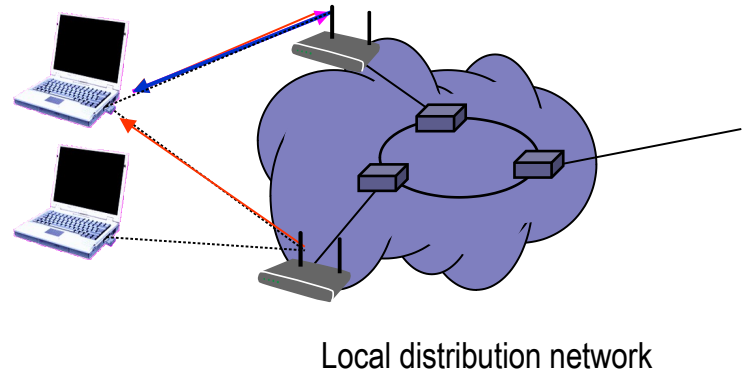

Process shown without reestablishing the security context!



# Handoff Time

---

- Total handoff time not deterministic but influenced by statistical variations of multiple protocol steps
  - Main variation by scanning procedure and period (~ 90%)
  - Most of the messaging may occur for scanning
  - Actual handoff extremely fast (Reassociation Request & Response)
  - WPA2 security adds another challenge
    - Keying material to be established at the new AP
- Possibilities to reduce the handoff time:
  - Reduce time needed to detect new AP with better radio link
    - periodic scanning, despite being connected to the old AP
    - selective scanning (using only a subset of all possible channels)
    - exploiting other information about neighbor Aps
  - Reduce time to establish security context at new AP
    - Fast roaming support, introduced by 802.11r, allows for pre-establishment of keys

# Layer 2 Mobility Considerations

---

- Link loss detection
  - The STA detects a low signal quality or no signal from the access point
    - Threshold decision (with hysteresis) (fast detection, commonly used)
  - The STA detects an increasing error rate of transmitted MAC frames
    - Slower than previous approach, but may be more predictive
- Requirement for the support of Layer 2 Mobility in WLAN:
  - All access points are connected directly over a single Ethernet
  - Inter access point communication happens by new AP informs infrastructure and previous AP by Layer-2 update frame on the wire
- For larger coverage areas this is not reasonable anymore
  - Layer 2 broadcast domains are of limited size
  - Multiple Distribution Systems are interconnected (usually with routers); Thus, layer 2 handoffs are not possible between the Distribution Systems
  - Solution by handoffs between the Distribution Systems are performed with higher layer mechanisms e.g. Mobile IP

---

Session Management

# **MAC MANAGEMENT MESSAGES**

# Basic MAC management messages attributes

---

- Beacon (9.3.3.2)
  - Timestamp, Beacon Interval, Capabilities, ESSID, Supported Rates, Traffic Indication Map, Parameters, ... (see Table 9-32)
- Probe Request (9.3.3.9)
  - SSID, Supported Rates, Parameters, ... (see Table 9-38)
- Probe Response (9.3.3.10)
  - Timestamp, Beacon Interval, Capabilities, SSID, Supported Rates, Parameters, .... (see Table 9-39)
    - Same as for Beacon except for TIM
- Authentication (9.3.3.11)
  - Authentication algorithm, Transaction number, Status code, Parameters, ... (see Table 9-40)
    - Format used for various actions depending on authentication algorithm
- Deauthentication (9.3.3.12)
  - Reason code
- Association Request (9.3.3.5)
  - Capability, Listen Interval, SSID, Supported Rates, ... (see Table 9-34)
- Association Response (9.3.3.6)
  - Capability, Status Code, AID, Supported Rates, ... (see Table 9-35)
- Reassociation Request (9.3.3.7)
  - Capability, Listen Interval, SSID, Current AP Address, Supported Rates, ... (see Table 9-36)
- Reassociation Response (9.3.3.8)
  - Capability, Status Code, AID, Supported Rates, ... (see Table 9-37)
- Disassociation (9.3.3.4)
  - Reason code

---

WLAN IEEE 802.11 aka Wi-Fi

# MAC FRAME FORMATS

# Overview

---

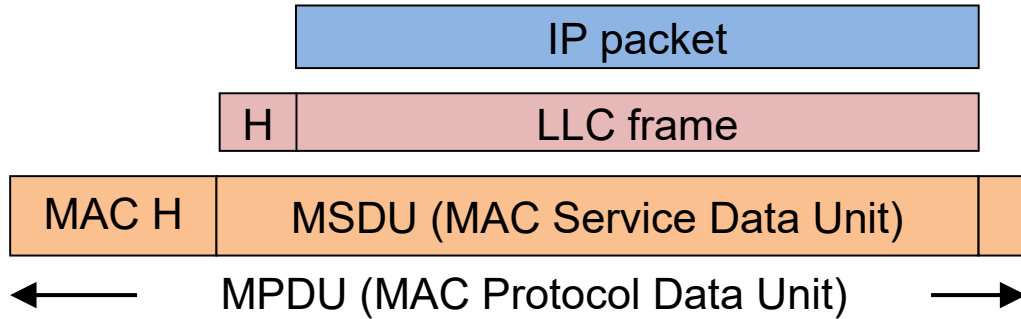

- Differences to widely known MAC data units, e.g. Ethernet:
  - Up to 4 address values
    - Necessary to handle the message transfer over the air
  - Different types of MAC data units
    - Data frames for transporting the MAC Service Data Unit
    - Control data units for medium access control, e.g. RTS, CTS, ACK
    - Management data units for the MAC Layer management messages
  - Duration ID field
    - Duration value for the transmission of the frame to allow NAV/virtual sensing
  - Sequence Control fields
    - Fragment Number for marking fragments
    - Sequence Number for marking MAC service data units

# IEEE 802.11 MAC Layer Frame Formats

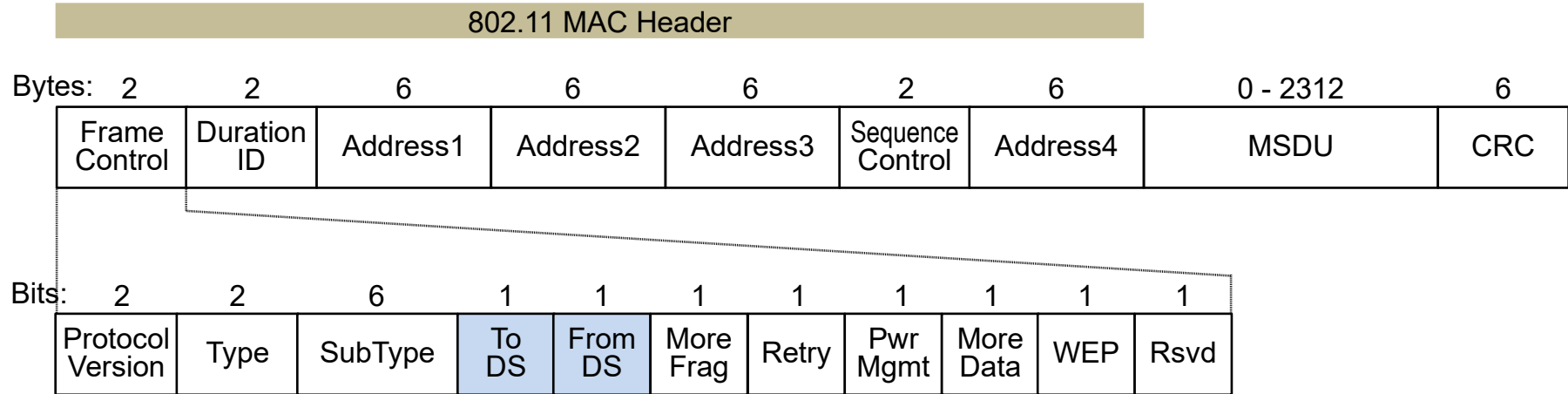

- MAC Header format differs per Type:
  - Control Frames (several fields are omitted)
  - Management Frames
  - MSDU Data Frames
- Includes Sequence Control Field for filtering of duplicate caused by ACK mechanism.

# Addressing

2	2	4	1	1	1	1	1	1	1	1
Protocol Version	Type	SubType	To DS	From DS	More Frag	Retry	Pwr Mgmt	More Data	WEP	Rsvd

To DS	From DS	Addr 1	Addr 2	Addr 3	Addr 4
0	0	DA	SA	BSSID	-
0	1	DA	BSSID	SA	-
1	0	BSSID	SA	DA	-
1	1	RA	TA	DA	SA

- Addr 1 = Destination of the radio frame
- Addr 2 = Transmitter Address (TA) identifies entity to receive the ACK frame
- Addr 3 = Entity on DS sending/receiving frame
- Addr 4 = Needed to identify the original source in case of WDS (bridging over the air).



# Header field descriptions

---

2	2	4	1	1	1	1	1	1	1	1
Protocol Version	Type	SubType	To DS	From DS	More Frag	Retry	Pwr Mgmt	More Data	WEP	Rsvd

- Type / Subtype:
  - MAC frames function (management frame, control frame, data frame)
- More Frag:
  - Indicates whether the frame has been split and more fragments are about to follow
- Retry
  - Indicates that this frame has been retransmitted
- Pwr Mgmt (Power Management)
  - Indicates that the station is in power save mode
- More Data
  - Indicates that more frames follow
- WEP
  - Indicates that the payload is encrypted

# Questions and answers

---



# Mac Layer Management Questions...

---

- 1) Which sequence of MAC management procedures is necessary for the establishment of a connection in IEEE 802.11
- 2) What is the purpose of scanning?
- 3) What are beacons in IEEE 802.11?
- 4) Explain the difference between active scanning and passive scanning.
- 5) What stands 'GAS' in IEEE 802.11 for?
- 6) What is the purpose of ANQP in IEEE 802.11?
- 7) How is ANQP related to GAS?
- 8) What is the purpose of IEEE 802.11 association procedure?
- 9) What is a Reassociation in IEEE 802.11?
- 10) Please shortly explain the MAC procedures for handover from one AP to another AP of the same ESS.
- 11) What are the limitations of Layer 2 mobility management?

---

WLAN IEEE 802.11 aka Wi-Fi

# QUALITY OF SERVICE

# Quality of Service by Traffic Prioritization

- Traffic is classified according to its importance and forwarding requirements
- Traffic Categories (TC) for prioritization
  - Differentiated channel access for frames with different user priorities
  - 8 different priorities, similar to IEEE 802.1Q specification

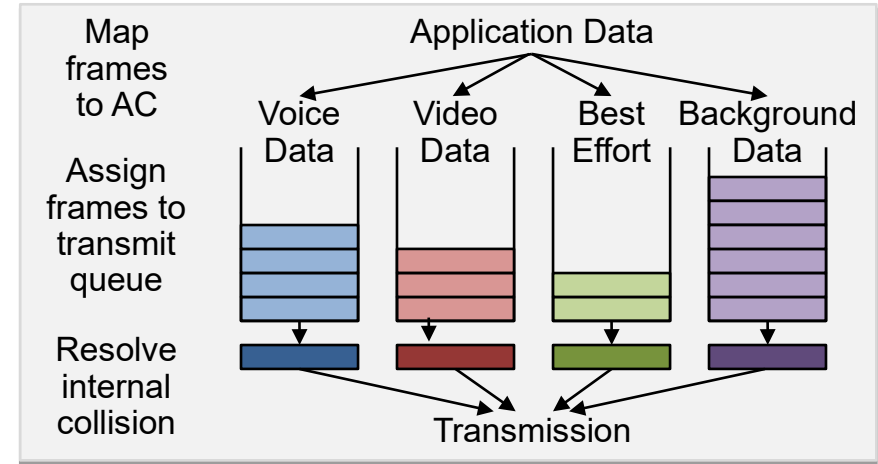

-	IEEE 802.1D/Q traffic types			IEEE 802.11 traffic types		
Priority	PCP	Acronym	Traffic Type	Access Category	Alternate AC	Designation
Lowest	1	BK	Background	AC_BK	• BK	Background
	0	BE	Best Effort	AC_BE	• BE	Best Effort
	2	EE	Excellent Effort	AC_BK	• BK	Background
	3	CA	Critical Applications	AC_BE	• BE	Best Effort
	4	CL	Controlled Load	AC_VI	• A_VI	Video
	5	VI	Video, < 100ms latency	AC_VI	• VI	Video
	6	VO	Voice, < 10ms latency	AC_VO	• VO	Voice
	Highest	7	NC	Network Control	AC_VO	• A_VO

# Legacy DCF does not provide traffic prioritization

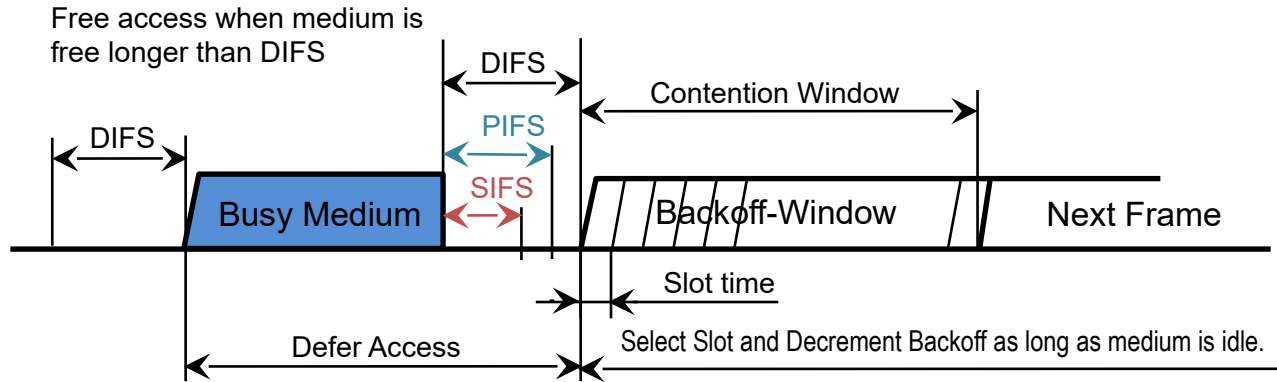

Standard	Slot time (µs)	DIFS (µs)
IEEE 802.11b	20	50
IEEE 802.11a/n/ac	9	34
IEEE 802.11g/n	9	28

SIFS: Short Inter Frame Space  
PIFS: PCF Inter Frame Space  
DIFS: DCF Inter Frame Space  
DIFS = SIFS + 2x Slot time

- All stations are waiting the same way for medium access by CCA
  - Medium has to be(come) idle.
  - Random backoff is used after a defer, resolving contention to avoid collisions.
    - Random backoff is an equally distributed value in the range 0..CW<sub>min</sub>; CW<sub>min</sub> = 15
  - Exponential backoff is used in the case of retransmissions
    - $CW = (2^k - 1)$  with  $k = n+4$  with  $n$  = number of retransmission; CW<sub>max</sub> = 1023
    - Efficient Backoff algorithm stable at high loads.
- DCF access procedure can't differentiate traffic categories.

# EDCF introduced by IEEE 802.11e allows for traffic prioritization

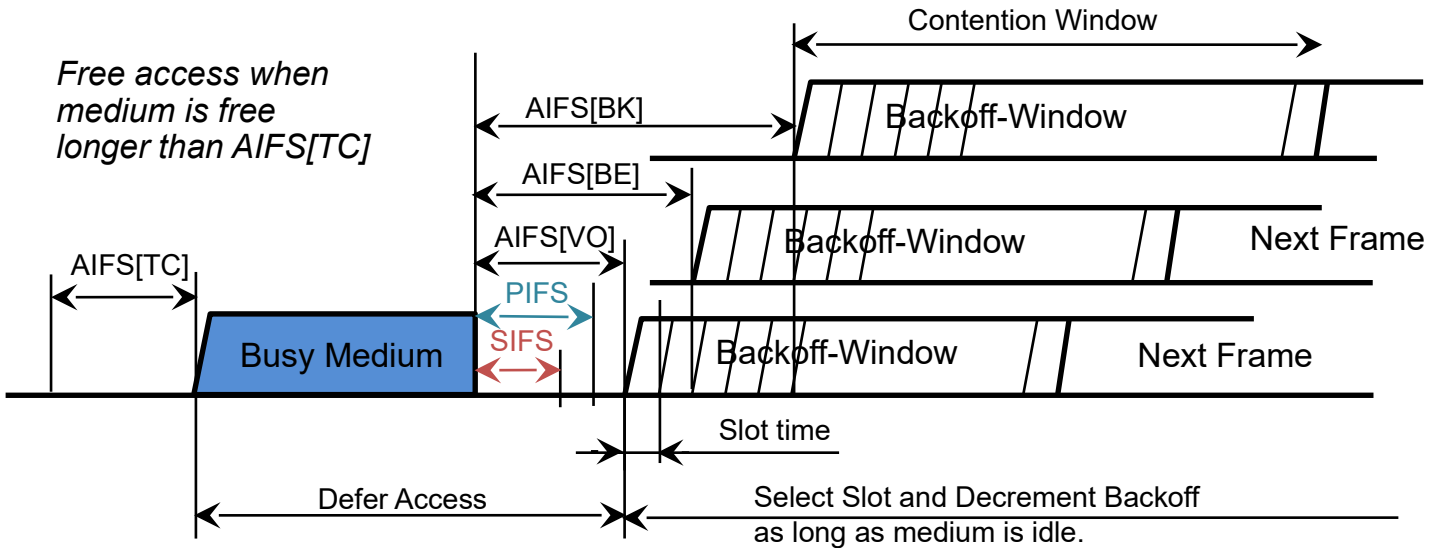

Standard	Slot time (μs)	DIFS (μs)
IEEE 802.11b	20	50
IEEE 802.11a/n/ac	9	34
IEEE 802.11g/n	9	28

SIFS: Short Inter Frame Space  
 PIFS: PCF Inter Frame Space  
 DIFS: DCF Inter Frame Space  
 $DIFS = SIFS + 2x \text{ Slot time}$

- Based on modification of CSMA/CA access function with shorter arbitration inter-frame space (AIFS) for higher priority packets.
- High priority traffic waits a little less before packets are sent
  - High-priority traffic has a higher chance of being sent than low-priority traffic

---

WLAN IEEE 802.11 aka Wi-Fi

# **WI-FI MULTIMEDIA (WMM)**



# QoS support by Wi-Fi Multimedia

---

- Wi-Fi Multimedia (WMM) defines the QoS capabilities of Wi-Fi.
  - WMM makes use of EDCAF for traffic prioritization.
  - Prioritized QoS identifies 4 traffic classes (Access Categories)
    - Aligned to the 8 priorities defined within IEEE 802.1Q.

Access Category	Description	802.1Q
WMM Voice Priority	Highest priority. Allows multiple concurrent VoIP sessions with low latency and jitter	7, 6
WMM Video Priority	Prioritize video traffic above other data traffic	5, 4
WMM Best Effort Priority	Traffic from legacy devices, or traffic from applications that do not require prioritization	3, 0
WMM Background Priority	Low priority traffic that does not require low latency or guaranteed throughput	1, 2

– Parameterized QoS is only partially supported by an admission control scheme.

# EDCF Parameters

- Levels of priority in EDCF are called Access Categories (ACs).
- Contention window (CW) set according to the traffic in AC
  - Wider window needed for categories with heavier traffic.
  - Window duration dependent of PHY mode.

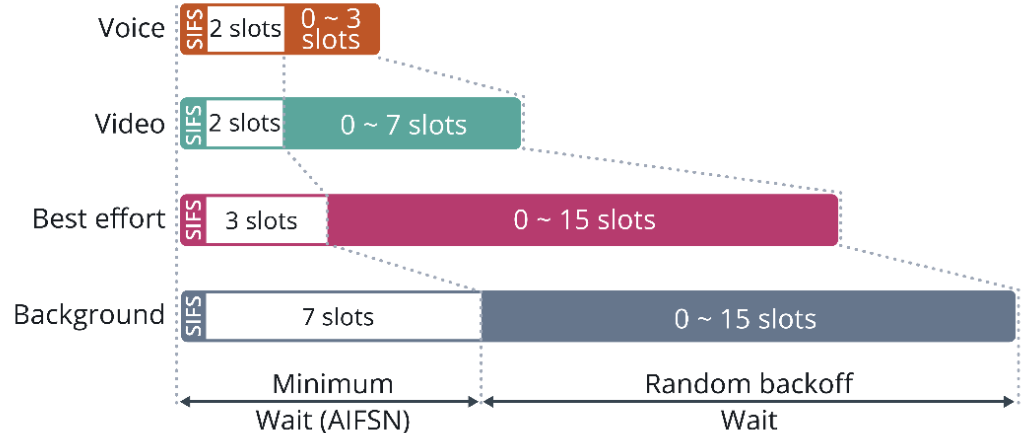

- Default EDCA Parameters for each AC (e.g. 802.11a/n)

Access Category	CWmin	CWmax	AIFSN	Max TXOP
Background (AC_BK)	15	1023	7	0
Best Effort (AC_BE)	15	1023	3	0
Video (AC_VI)	7	15	2	3.008ms
Voice (AC_VO)	3	7	2	1.504ms
Legacy DCF	15	1023	2	0

# Parameterized QoS for Traffic Stream

- QoS is characterized by a set of parameters, called Traffic Specification (TSPEC)
- A Traffic Stream (TS) is set up between transmitter and receiver
  - TSPEC specifies service rate, delay and jitter requirements of particular traffic flows.

Octets: 3	2	2	4	4	4	4	4	4
TS Info	Nominal MSDU Size	Maximum MSDU Size	Minimum Service Interval	Maximum Service Interval	Inactivity Interval	Suspension Interval	Service Start Time	Minimum Data Rate
4	4	4	4	4	2		2	
Mean Data Rate	Peak Data Rate	Maximum Burst Size	Delay Bound	Minimum PHY Rate	Surplus Bandwidth Allowance		Medium Time	

- Management commands for negotiation of TSPECs between STA and AP:
  - ADDTS Request
  - ADDTS Response
  - DELTS
- After successful negotiation of a TSPEC a STA can contend for a TXOP and then leverage the medium up to the TXOP time limit.
  - TXOP time limits of an AP are conveyed in the beacon.

# Improving channel utilization and efficiency

---

- **Transmission Opportunities**
  - TXOP is a time interval during in which a station can send as many frames as possible
    - But staying within the maximum duration of the TXOP
    - Frames too large for a single TXOP are fragmented into smaller frames.
    - TXOPs reduces the problem of low rate stations gaining too much channel time
- **Block Acknowledgement**
  - Group of frames received consecutively acknowledged by a BlockAck
- **Direct Link Protocol (DLP)**
  - STA-to-STA transmission in the infrastructure mode
    - DLP handles the problems related, e.g. power saving of the receiving STA
- **Unscheduled Asynchronous Power Save Delivery (U-APSD)**
  - Legacy power-save mode is based on DIFS without protection of medium access
  - Allows a STA to retrieve unicast QoS traffic within one TXOP buffered in the AP by sending trigger frames.
  - U-APSD exchange of frames occurs with SIFS separation
    - Medium remains locked during the exchange.

---

WLAN IEEE 802.11 aka Wi-Fi

# **WI-FI QOS IN ACTION**

# WMM performance: Comparison DCF vs. EDCF

- E.g: Sunghyun Choi; J. del Prado; Sai Shankar N; S. Mangold, IEEE 802.11e contention-based channel access (EDCF) performance evaluation, IEEE International Conference on Communications, 2003.
  - [http://www.cs.jhu.edu/~baruch/RESEARCH/Research\\_areas/Wireless/wireless-public\\_html/class-papers/802.11e-performance.pdf](http://www.cs.jhu.edu/~baruch/RESEARCH/Research_areas/Wireless/wireless-public_html/class-papers/802.11e-performance.pdf)
  - Fixed data rate of 802.11b 11 Mbps; 2 video, 4 voice, and 4 data stations
  - Buffer size: 20 kbit for voice, 1Mbit for video, infinite for data
  - Traffic pattern and default EDCF parameters:

Type	Inter-arrival Time (Avg. in sec)		Frame Size (bytes)	Data Rate (Mbps)		
Voice	Constant (0.02)		92	0.0368		
Video	Constant (0.001)		1464	1.4		
Data	Exponential (0.012)		1500	1.0		

Type	Prior.	AC	AIFS	CWmin	CWmax	TXOP limit (msec)
Voice	7	3	PIFS	7	15	3
Video	5	2	PIFS	15	31	6
Data	0	0	DIFS	31	1023	0

# DCF vs. EDCF

- Throughput comparison
  - Higher video throughput with EDCF

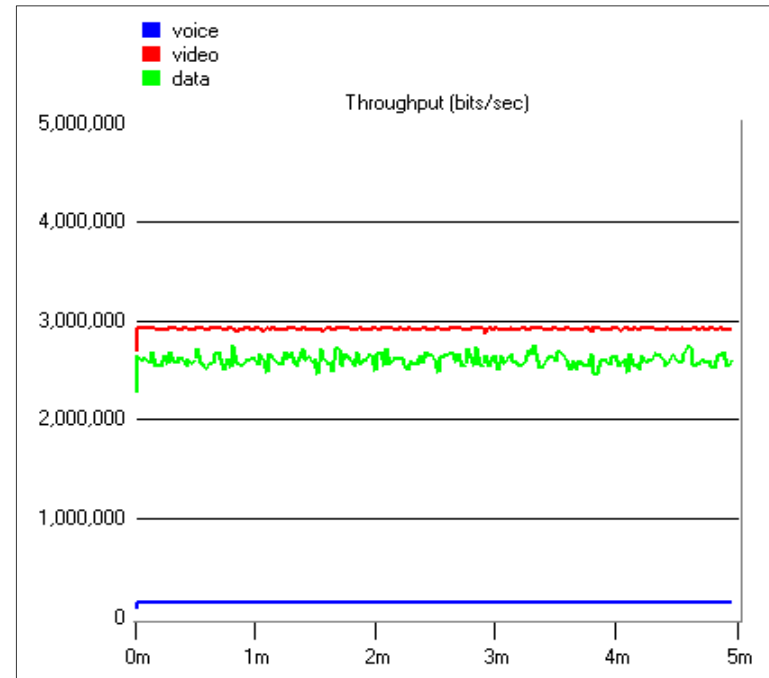
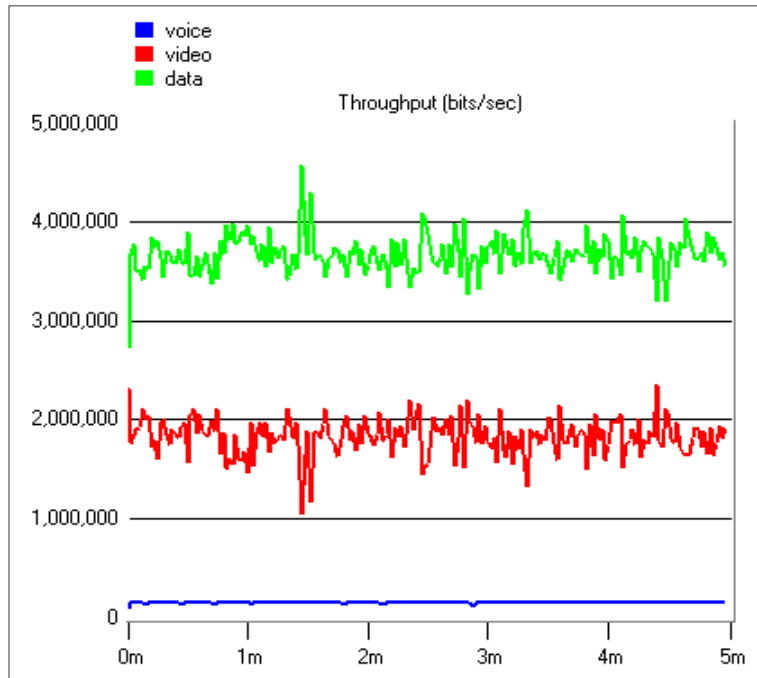

# DCF vs. EDCF

- Data dropping rate comparison
  - Video drop virtually gone with EDCF

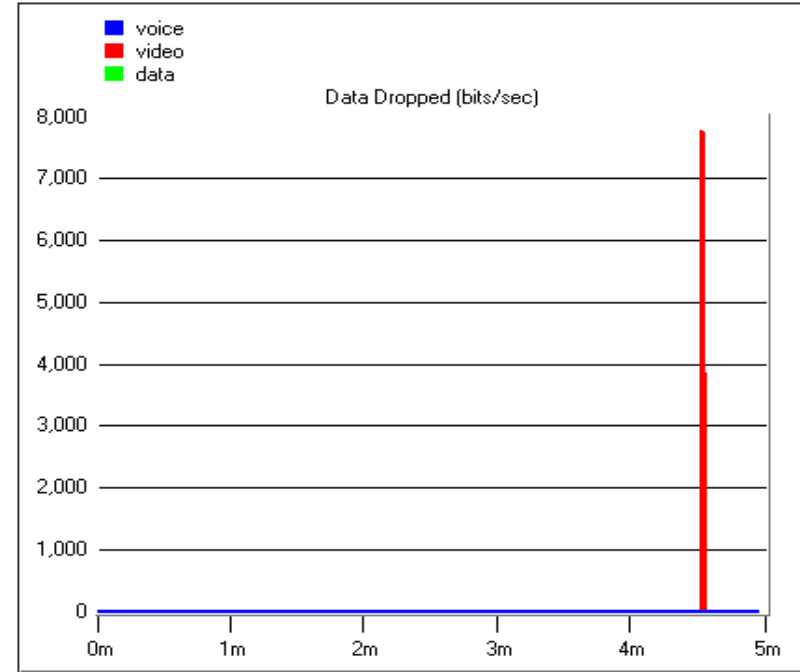
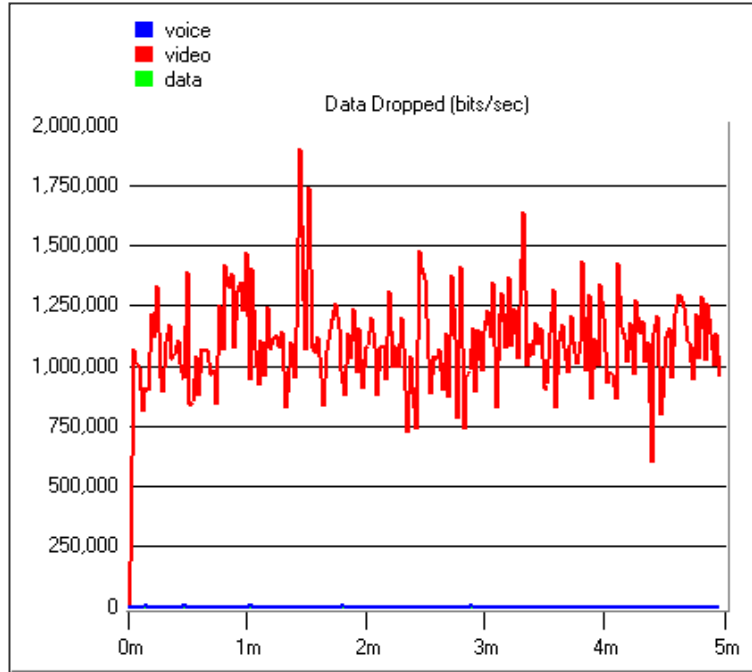



# DCF vs. EDCF

- Delay comparison
  - Voice and video delays significantly reduced

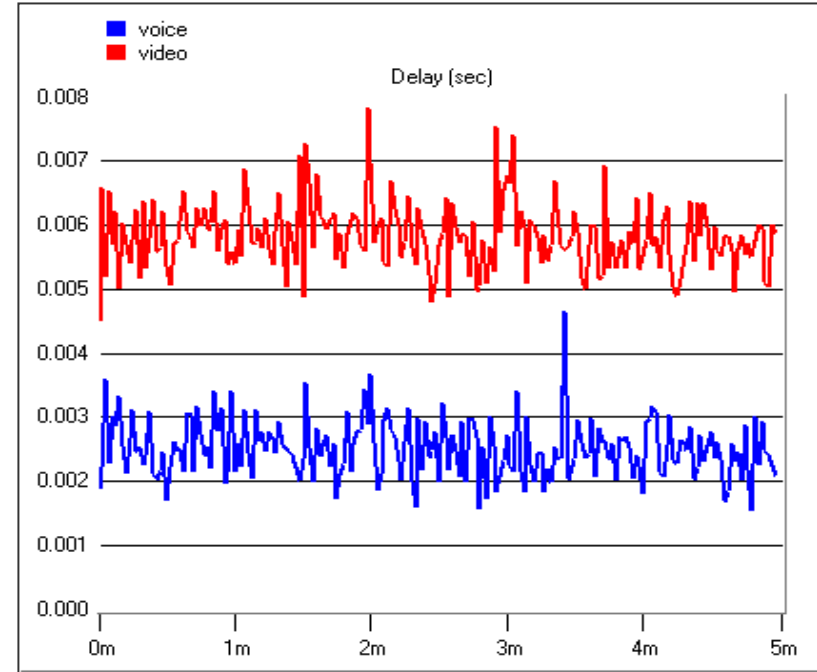
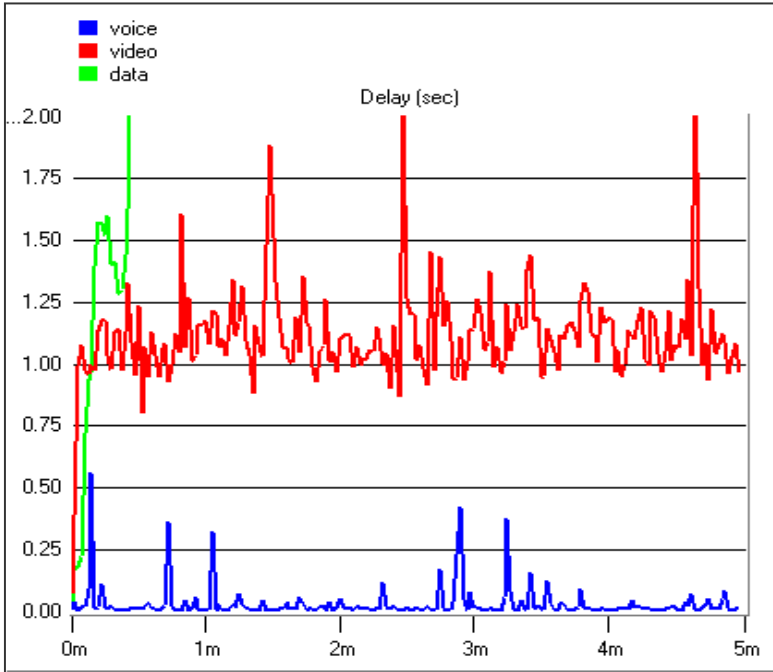

---

WLAN IEEE 802.11 aka Wi-Fi

# **WI-FI CERTIFIED QOS MANAGEMENT**

# How to assign User Priorities to packets?

- User Priority needs to be determined based on the higher layer QoS requirements of the application or service.
- Most commonly, applications signal this intent via DSCP marking within the IP packet header, which can then be mapped to a User Priority.
- However, there are many scenarios in which the appropriate DSCP marking is not, or cannot, be applied.

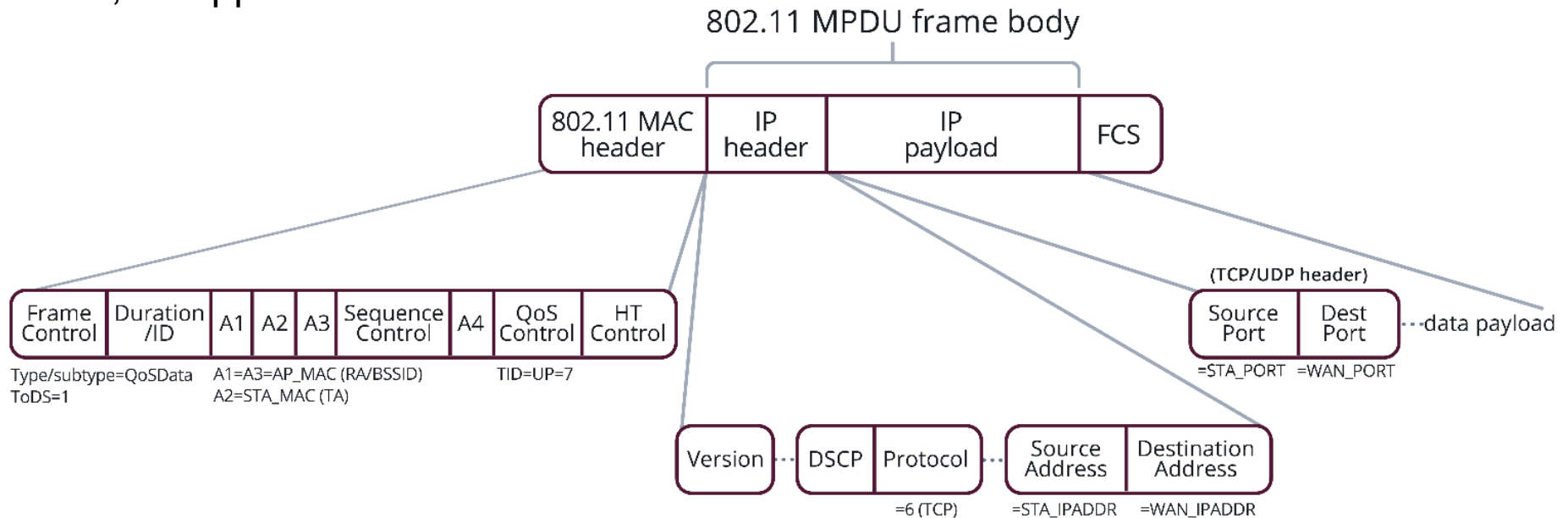

# Wi-Fi CERTIFIED QoS Management

---

- Wi-Fi QoS Management certification is available for client devices and access points (APs). The program comprises two main features, which are based on capabilities defined in IEEE Std 802.11-2020:
  - Mirrored Stream Classification Service (MSCS) enables a client device to manage AP QoS treatment of downlink IP flows using QoS mirroring
  - Differentiated Service Code Point (DSCP) mapping enables a network manager to configure the mapping between the DSCP marking in the IP packet headers and the over-the-air QoS treatment on both APs and client devices
- Both of these features leverage WMM, which is based on IEEE 802.11 QoS mechanisms. Support for both features is mandatory for Wi-Fi QoS Management certification.
- The Wi-Fi QoS Management program builds on WMM by enabling both APs and client devices to request identified IP flows to be assigned to an access category for specific QoS treatment.

# Mirrored Stream Classification Service

---

- MSCS is defined in IEEE 802.11-2020.
  - Simple means for a client device to request its AP to assign downlink IP flows destined to that client device to the desired access categories.
  - Based on the concept of “mirrored,” or “reflective,” QoS, where the AP derives QoS rules for downlink IP flows by monitoring the corresponding uplink IP flows sent by the client device.
    - Done by monitoring the IP header and the User Priority value in the 802.11 MAC header.
- MSCS is designed for situations where the downlink IP flows do not have appropriate DSCP marking,
  - Lack of appropriate DSCP marking is a frequent scenario for downlink IP flows that originate on the public internet.
- MSCS involves a single request/response exchange to negotiate the MSCS parameters, which is done either at association or at any time post-association.
  - Client device does not need to request QoS treatment for each flow individually and does not need to determine an IP tuple classifier for each IP flow.
  - Very efficient in scenarios where applications and services generate many short-lived IP sessions and/or the IP tuples of data flows are a-priori unknown, for example, due to DNS load balancing.

# MSCS signaling

---

- Capabilty signaling

- APs and client devices indicate support for MSCS in the Extended Capabilities element in (Re)Association Request and Response frames.
  - APs also indicate support for MSCS in Beacon and Probe Response frames.

- Setup procedures

- Always initiated by the client device
  - Either by sending an MSCS Request frame to the AP postassociation,
  - Or if supported by sending a request embedded in a (Re)Association Request frame at association time.
- Request frame contains an MSCS Descriptor element which specifies the parameters
  - Request Type
    - add/change/remove
  - User Priority bitmap
    - List of UP priorities to be monitored uplink to retrieve downlink QoS rules, usually only 4,5,6,7 (Voice & Video) to avoid exaggerated processing demand at AP
  - User Priority limit
    - Maximum limit for the User Priority values that the AP applies in downlink QoS rules to allow for expedited data despite prioritization (e.g. in enterprise configurations)
  - Stream timeout
    - Minimum period of time for which the AP is required to maintain a downlink QoS rule, typically in the range of 60 s or less. If a prioritized downlink pauses and the rule is deleted, the rule is re-established through the first packet of that stream going upstream.

# MSCS signaling, cont.

---

- Traffic classification Mask element
  - Indicates a list of IP header fields that the AP has to use to define a downlink QoS rule, e.g. 4 indicating IP and higher layer parameters leading to the QoS rule being based on the full IP 5-tuple (Source and Destination IP Address and Ports, and Protocol / Next Header).
- Response frame of AP if request accepted
  - AP activates MSCS for that client device, or updates the MSCS parameters if already activated, and maintains the MSCS state for each client device individually.
  - If requested at association, AP responds with MSCS Descriptor element 'success' in (Re)Association Response frame.
  - If requested post-association, AP responds with a MSCS Response frame indicating success.
- If AP does not accept MSCS request
  - AP provides a status code of the reason for rejection, such as insufficient processing resources, or unsupported TCLAS Mask parameters. Optionally AP responds with alternative set of MSCS parameters that it would be prepared to accept
    - If alternative set of MSCS parameters is sufficient for client device, it might resubmit MSCS request with alternative parameters.
- MSCS termination and roaming
  - AP and client device can terminate an active MSCS at any time by sending an unsolicited MSCS Response frame to that client device, including a status code value indicating the reason for the termination.
  - A client device can terminate MSCS by sending an MSCS Request frame with Request Type 'remove'.
  - Any active MSCS between an AP and client device is implicitly terminated when the client device is no longer associated with the AP, or reassociates with the same AP.
  - Client device needs to request activation of MSCS with the new AP in the target BSS during or immediately after the roam (re)association
  - Note: Downlink IP flows are not assigned the expected User Priority immediately after a roam until the client device has sent at least one packet to the target BSS in the corresponding uplink IP flow so that the AP can generate the corresponding rule.

# DSCP mapping

---

- Certain DSCP marking policies may be configured as part of network wide QoS management
  - In managed enterprise and carrier Wi-Fi networks, downlink traffic might be DSCP marked at source for servers managed by the enterprise or carrier, or may be marked at ingress to the network based on classification rules for traffic originating from third party servers on the public Internet.
  - Network managers could also manage the DSCP marking of uplink traffic at source using Group Policy Objects (GPO) or Mobile Device Management (MDM) tools deployed on managed client devices, or mobile applications apply specific DSCP marking to QoS sensitive uplink flows by default,
- Wi-Fi QoS Management certified APs and client devices are required to support the default DSCP-to-UP Mapping table defined in IETF RFC 8325, and also to support the QoS Map feature defined in IEEE 802.11 to indicate exceptions to that default mapping.
- A QoS Map feature allows the network manager to override the QoS treatment of both downlink and uplink IP packets with a given DSCP marking.
  - When the QoS Map feature is enabled on an AP or client device and a non-default DSCP-to-UP Mapping table is configured, the device must use that table for its own transmissions, instead of the IETF RFC 8325 default mapping table
- When QoS Map is used to configure a non-default DSCP-to-UP Mapping table on a client device, the configuration applies for the duration of the client device association to that basic service set identifier.
  - If that client device then roams to another BSS in the network, the AP in the target BSS must configure the same mapping table using QoS Map. The configuration must be done during or immediately after the roam (re)association.



# Questions and answers

---



## Quality of Service questions...

---

- 1) What does EDCF mean, and which enhancements were added to DCF?
- 2) How does Enhanced Distributed Coordination Function (EDCF) ensure backward compatibility to DCF?
- 3) By which standard amendment was QoS support added to IEEE 802.11?
- 4) What is AIFS?
- 5) How many traffic categories does exist in IEEE 802.1Q, and how many does WMM support?
- 6) How are the QoS classes denoted that are supported by WMM?
- 7) Through which method are traffic classes realized in IEEE 802.11?
- 8) What does TSPEC mean, and for what is it used?
- 9) What is the purpose of Wi-Fi QoS management?
- 10) Which two main features are provided through Wi-Fi QoS management?

---

WLAN IEEE 802.11 aka Wi-Fi

**END OF PART 2**

# Anything left for today?

---



See you again next week 😊.